

MODELS:

# SRCOOL12K, SRXCOOL12KEU & SRXCOOL12KEUB

SmartRack® Self-Contained Portable Air Conditioners



12,000 BTU



Effective Spot Cooling



Zero-Maintenance Design



Filters and Dehumidifies Air



Intuitive LCD Screen

- A** Control Panel
- B** Recessed Handles
- C** Air Filter Covers
- D** Drainage Outlet
- E** Casters
- F** Front Panel
- G** Cool Air Output
- H** Louvered Vent Insert (Pre-Installed)
- I** Cooling Duct Adapter
- J** Rear Panel
- K** Warm Air Exhaust
- L** Evaporator Drainage Outlet
- M** Evaporator Filter
- N** Condenser Filter
- O** Remote Monitoring Jack

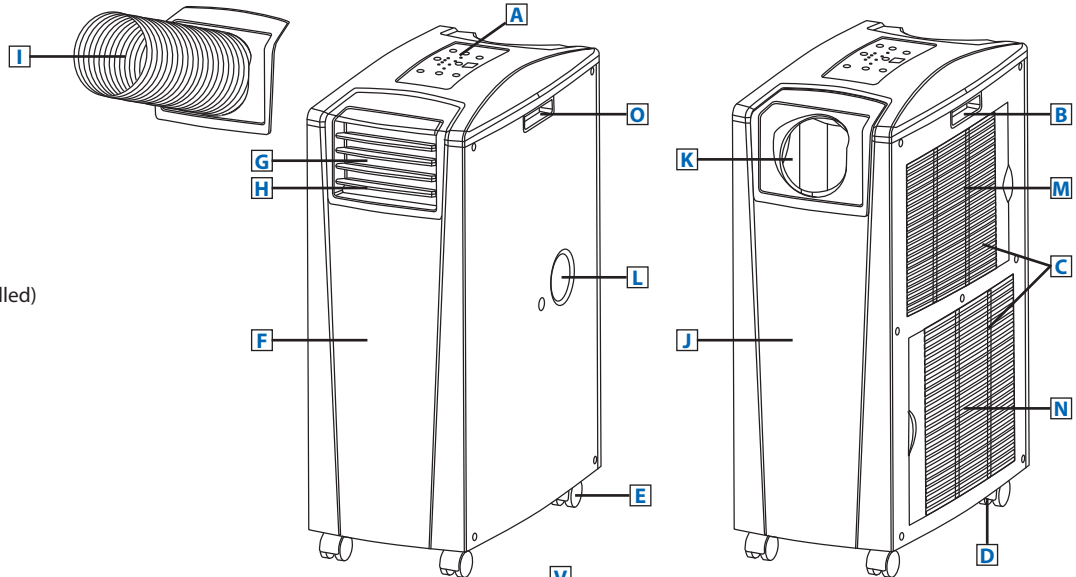

## Control Panel

- P** "POWER" Button
- Q** "FUNCTION" Button
- R** "TIMER" Button
- S** "FAN SPEED" Button
- T** "QUIET" Button
- U** Temperature Control Buttons
- V** LCD Screen
- W** Operating Mode LEDs
- X** Fan Speed Mode LEDs

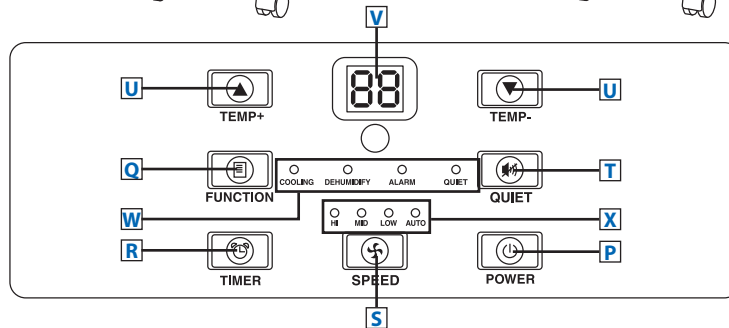

## Specifications

Models	SRCOOL12K, SRXCOOL12KEU & SRXCOOL12KEUB
Cooling Capacity	12,000 BTU / 3.5kW
Power Consumption	1400W Max
Input Cord / Connector	6 ft. / NEMA 5-15P (SRCOOL12K) / Schuko CEE7 (SRXCOOL12KEU) / British (SRXCOOL12KEUB)
Unit Dimensions (H x W x D)	30.32 x 11.87 x 20.08 in. / 770 x 301.5 x 510.1 mm
Shipping Dimensions (H x W x D)	33.46 x 15.16 x 29.13 in. / 850 x 385 x 740 mm
Unit Weight	74 lb. / 33.56 kg
Shipping Weight	83 lb. / 37.64 kg
Standards	SRCOOL12K: UL 484, CSA, RoHS; R410a Refrigerant / SRXCOOL12KEU, SRXCOOL12KEUB: CE, RoHS; R290 Refrigerant



- Offers 12,000 BTU of hot-spot and general room cooling with two exchangeable vent styles
- Compact, portable, self-contained design with built-in evaporator reduces maintenance—no water collection tank or drain required
- Filters and dehumidifies air to protect equipment
- Features remote control, management and true spot cooling capabilities (requires SRCOOLNETLX Web Management Accessory, sold separately)

**SEE NEXT PAGE FOR DETAILED UNIT MEASUREMENTS**

**TRIPP-LITE**  
by **EAT•N**

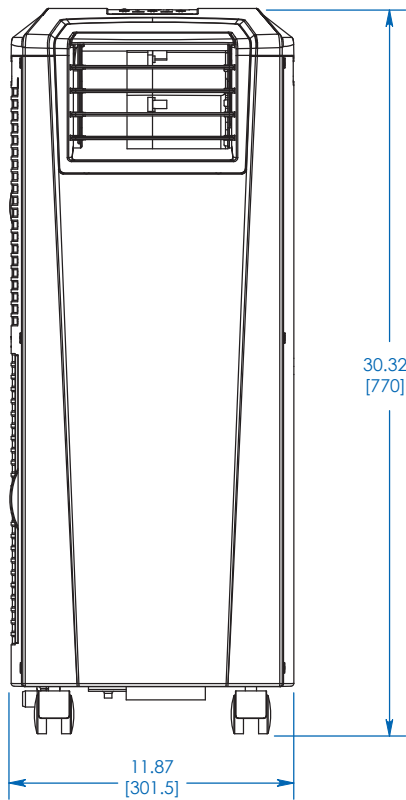

FRONT VIEW

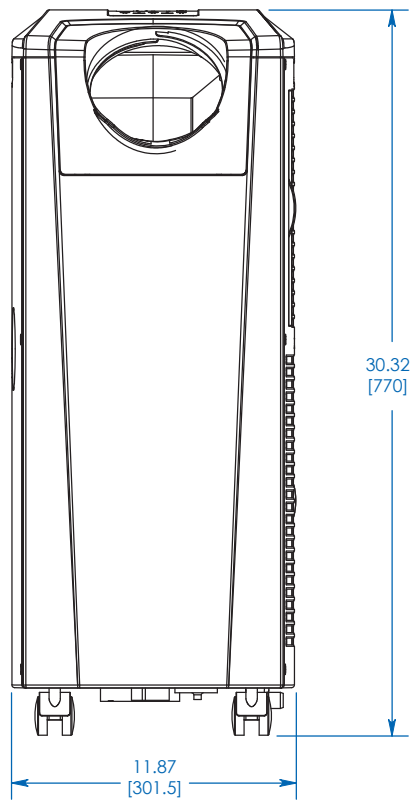

BACK VIEW

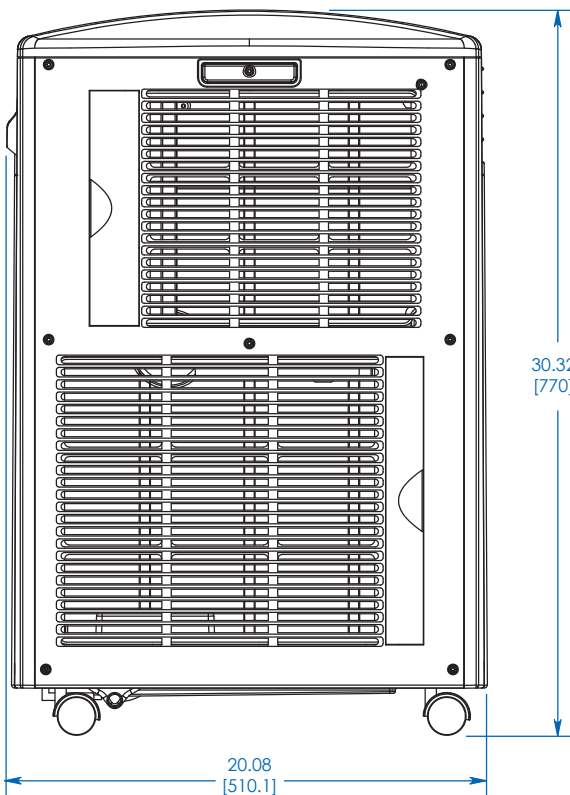

SIDE VIEW

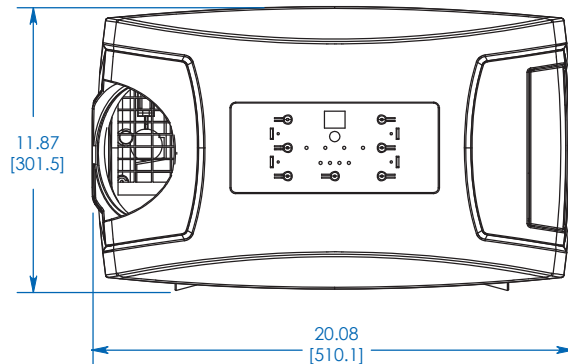

TOP VIEW

**Dimensions: inches [mm]**

We have a policy of continuous improvement. Specifications are subject to change without notice. Photos and illustrations may differ slightly from actual products.

Models:  
**SRCOOL12K,**  
**SRXCOOL12KEU &**  
**SRXCOOL12KEUB**  
**TRIPP-LITE**  
 by **EATON**

1111 W. 35th Street  
 Chicago, IL 60609 USA  
 773.869.1234  
 tripplite.com

**About Tripp Lite by Eaton**

Tripp Lite joined the Eaton family in March 2021. Eaton has long been a premier name in backup power and power management. The acquisition of Tripp Lite transforms Eaton's distributed IT infrastructure and connectivity equipment capabilities. Combining our product strengths and expert personnel allows us to offer comprehensive and innovative solutions for critical power and digital infrastructure applications, backed by quality, service and support you can trust. Learn more at [tripplite.com/byEaton](http://tripplite.com/byEaton).