

Monitor Mount for Slat Wall System (DMSW1332LTAA)

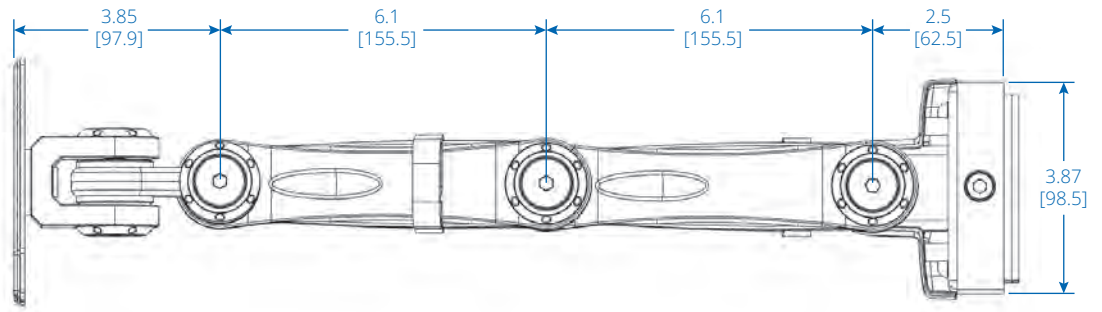

TOP VIEW

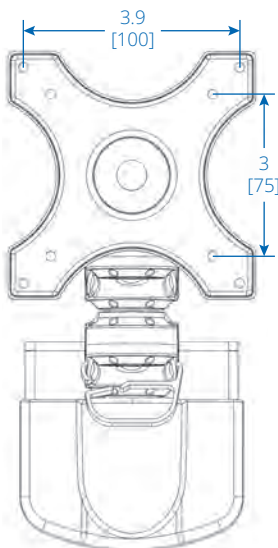

FRONT VIEW

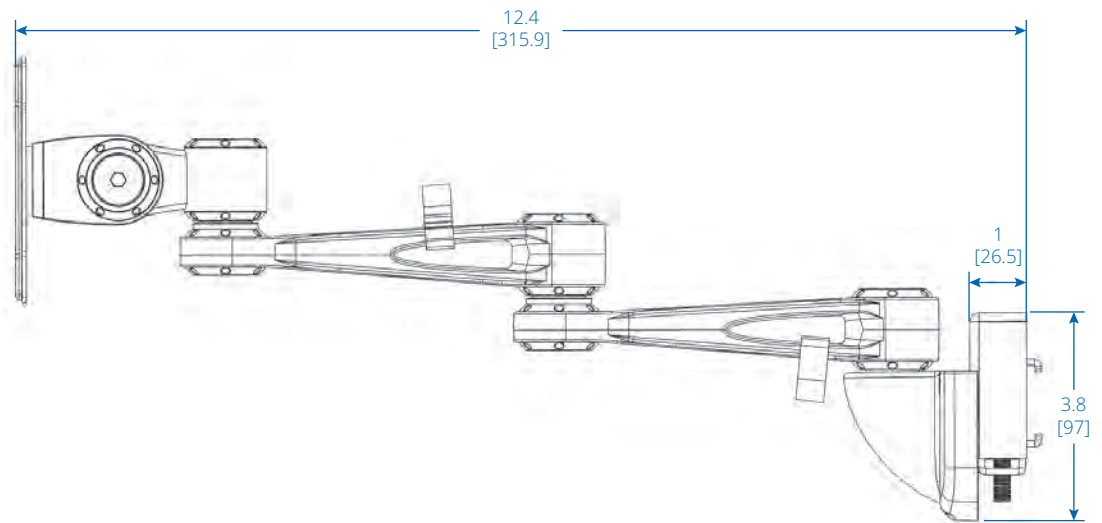

SIDE VIEW

Dimensions: INCHES [mm]

Learn more at Tripplite.Eaton.com