

MODEL:

SRQ24U

SmartRack® 24U Sound Proof Server Rack



24 Rack Units



1,000 lb. Stationary Load Capacity



1,000 lb. Rolling Load Capacity



Heavy-Duty Casters



Locking Front and Rear Doors



Standard 19 in. Rack Width



Adjustable Mounting Rails

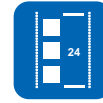

Square Hole Mounting



Foam Sound-Dampening Baffles

- A** Locking Front Doors with Foam Sound-Dampening Baffles
- B** Adjustable Mounting Rails
- C** Cool-Air Intakes
- D** Non-Removable Side Panels with Foam Sound-Dampening Baffles
- E** Locking Rear Doors with Foam Sound-Dampening Baffles
- F** 6-Outlet 15A Power Strip
- G** Brush Strip Plate
- H** Exhaust Fans
- I** Hot-Air Chambers
- J** Hot-Air Exhaust Vents
- K** Casters
- L** Keys (for front and rear doors)

Also includes: rack-mounting hardware, shipping materials and owner's manual

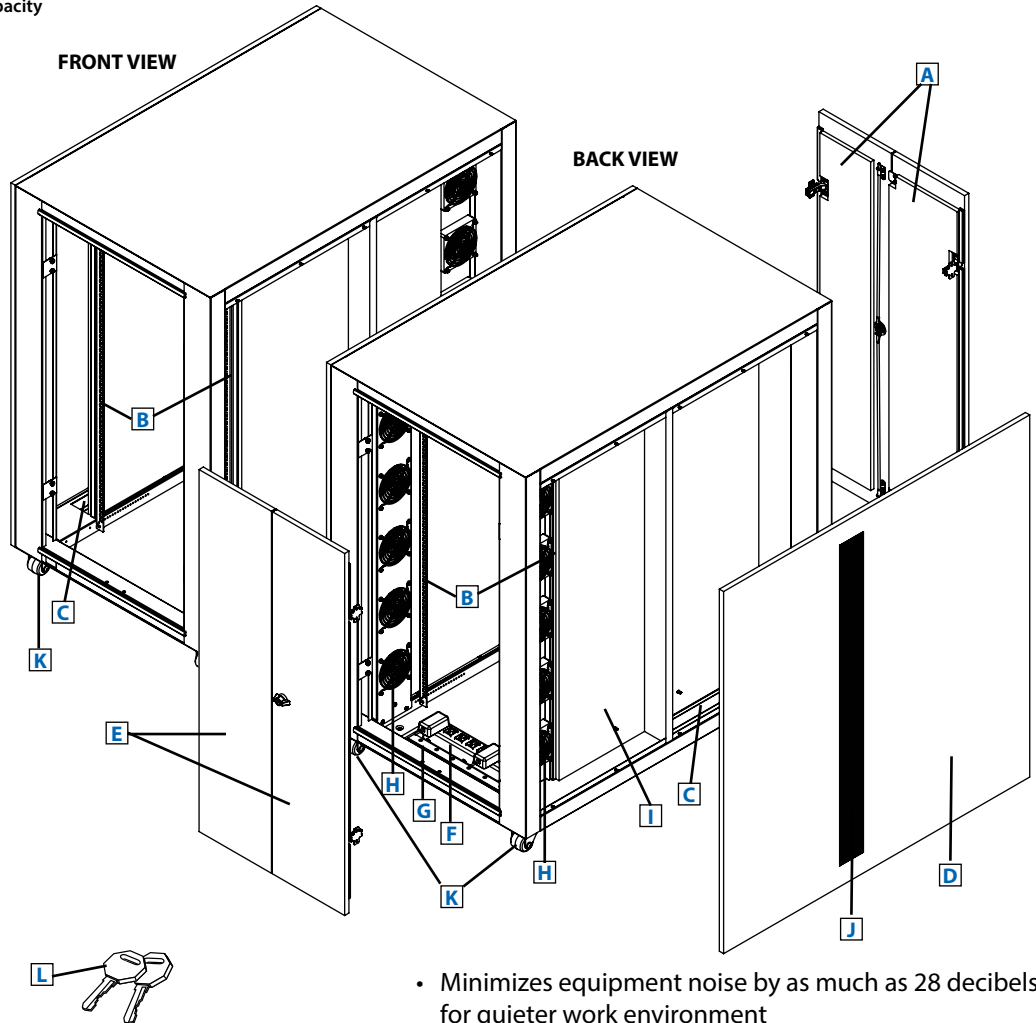

- Minimizes equipment noise by as much as 28 decibels for quieter work environment
- Floor panel intakes and built-in fans keep equipment cool to maintain top performance
- Steel/MDF cabinet locks securely to help prevent equipment damage or theft
- Ships fully assembled for immediate deployment and equipment mounting

SEE NEXT PAGE FOR DETAILED UNIT MEASUREMENTS



1111 W. 35th Street
Chicago, IL 60609 USA
773.869.1234
www.tripplite.com

Specifications

Model	SRQ24U
Rack Spaces	24U
Stationary Load Capacity	1,000 lb. / 454 kg
Rolling Load Capacity	1,000 lb. / 454 kg
Unit Dimensions (H x W x D)	49.1 x 30 x 46.7 in. / 1246 x 762 x 1186 mm
Shipping Dimensions (H x W x D)	54.3 x 32 x 48.7 in. / 1379 x 812 x 1237 mm
Unit Weight	297 lb. / 134.7 kg
Shipping Weight	330 lb. / 149.7 kg
Standards	EIA/ECA-310-E; RoHS

Tripp Lite has a policy of continuous improvement. Specifications are subject to change without notice.



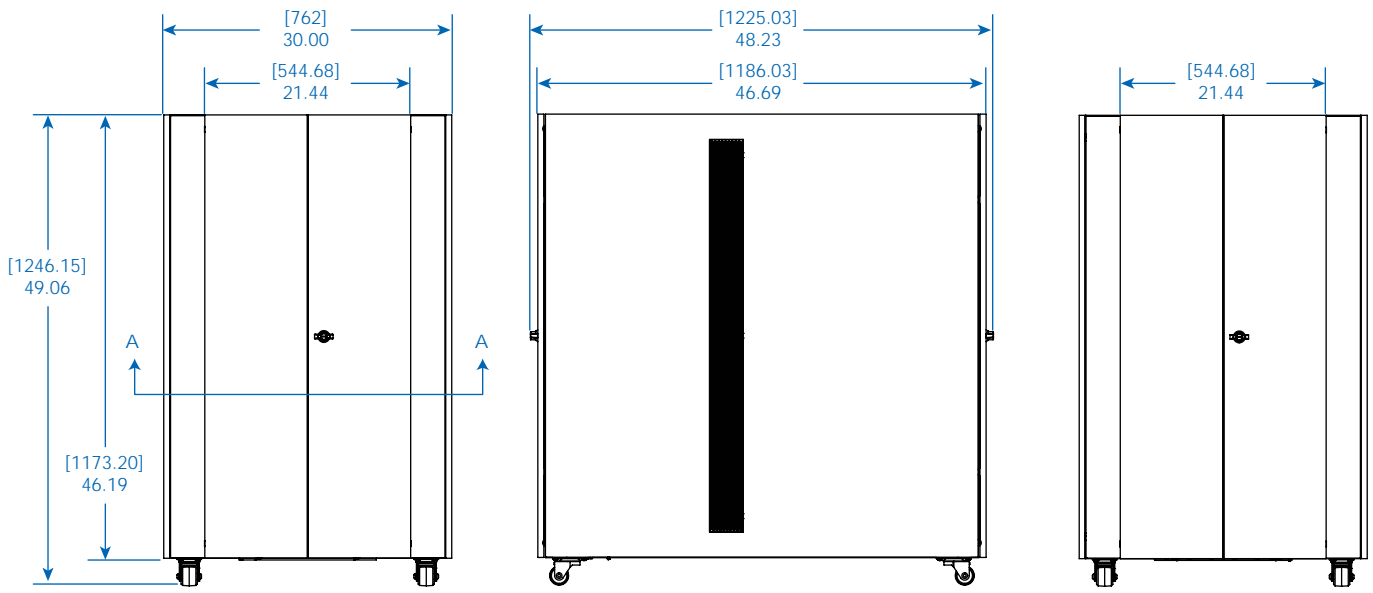

FRONT VIEW

SIDE VIEW

BACK VIEW

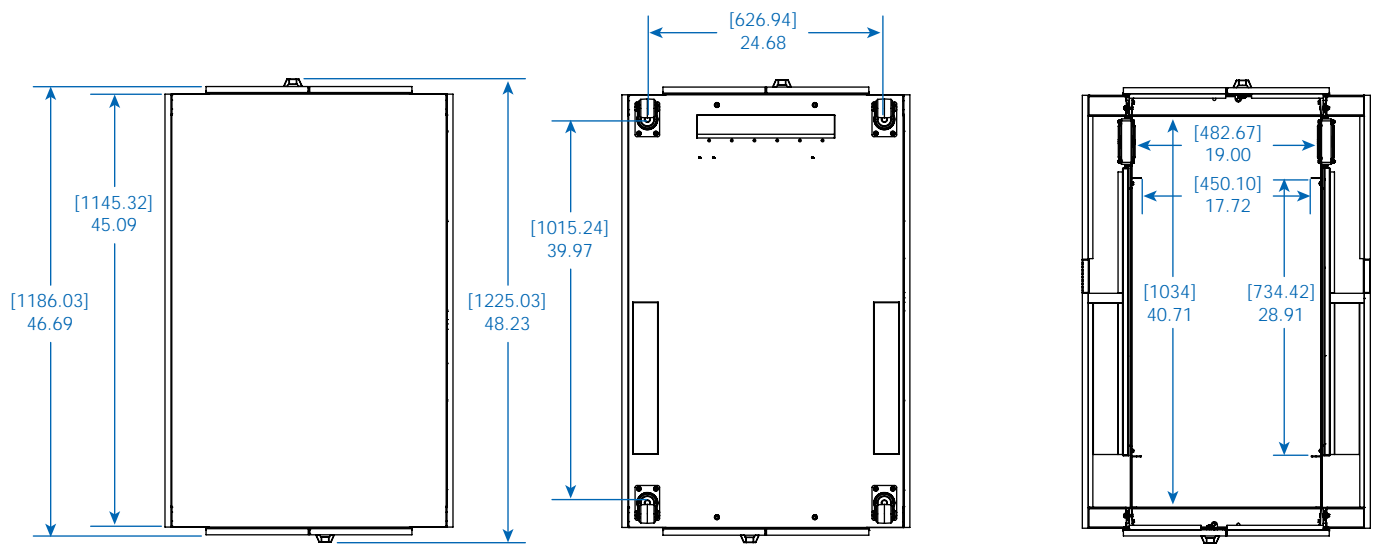

TOP VIEW

BOTTOM VIEW

CROSS-SECTION A

Dimensions: [mm] INCHES

Tripp Lite has a policy of continuous improvement. Specifications are subject to change without notice.

MODEL:
SRQ24U



1111 W. 35th Street
Chicago, IL 60609 USA
773.869.1234

www.triplite.com