

MODEL:

PDU3EVS6G60

3-Phase Switched 0U Vertical PDU



200/208/240V
3-Phase Input



IEC 309 60A
Blue (3P + E)
Plug



200/208/240V
Single-Phase
Output



30 Outlets



10kW Load
Capacity



Touchscreen
LCD



HTML5
Network
Interface



0U
Rack Mount



Toolless
Mounting
Buttons

- A** Color Touchscreen LCD
- B** C13 and C19 Outlets with Multi-Function LEDs
- C** 20A 2-Pole Hydraulic Magnetic Circuit Breakers
- D** C13 and C19 Plug-Lock Inserts
- E** Removable Mounting Brackets
- F** Toolless Mounting Buttons with Removable 90° Rotation Brackets
- G** 6 ft. Input Power Cord
- H** IEC 309 60A Blue (3P + E) Input Plug
- I** LX Platform Interface
- J** USB-B Port (for Direct Console Access)
- K** USB-A Ports (for EnviroSense2 Sensors)
- L** RJ45 Configuration Port
- M** Ethernet Port
- N** Network Interface Reset Button

Not Shown: Configuration Cable, Owner's Manual

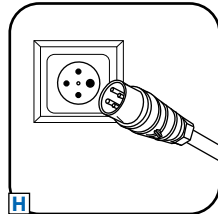

AC Input Connection: Insert IEC 309 60A Blue (3P + E) plug into compatible utility, generator or UPS outlet.

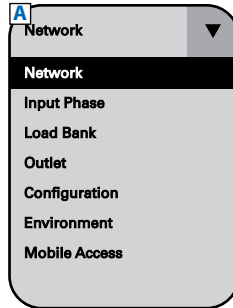

Color Touchscreen LCD: Easily toggle between menus to monitor input current level per phase, output current per load bank and per outlet, environmental sensor data and network information. It also generates a unique QR code to allow access to the switchable PDU through a mobile device.

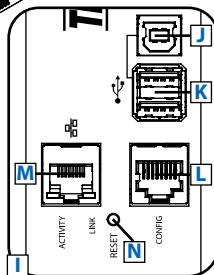
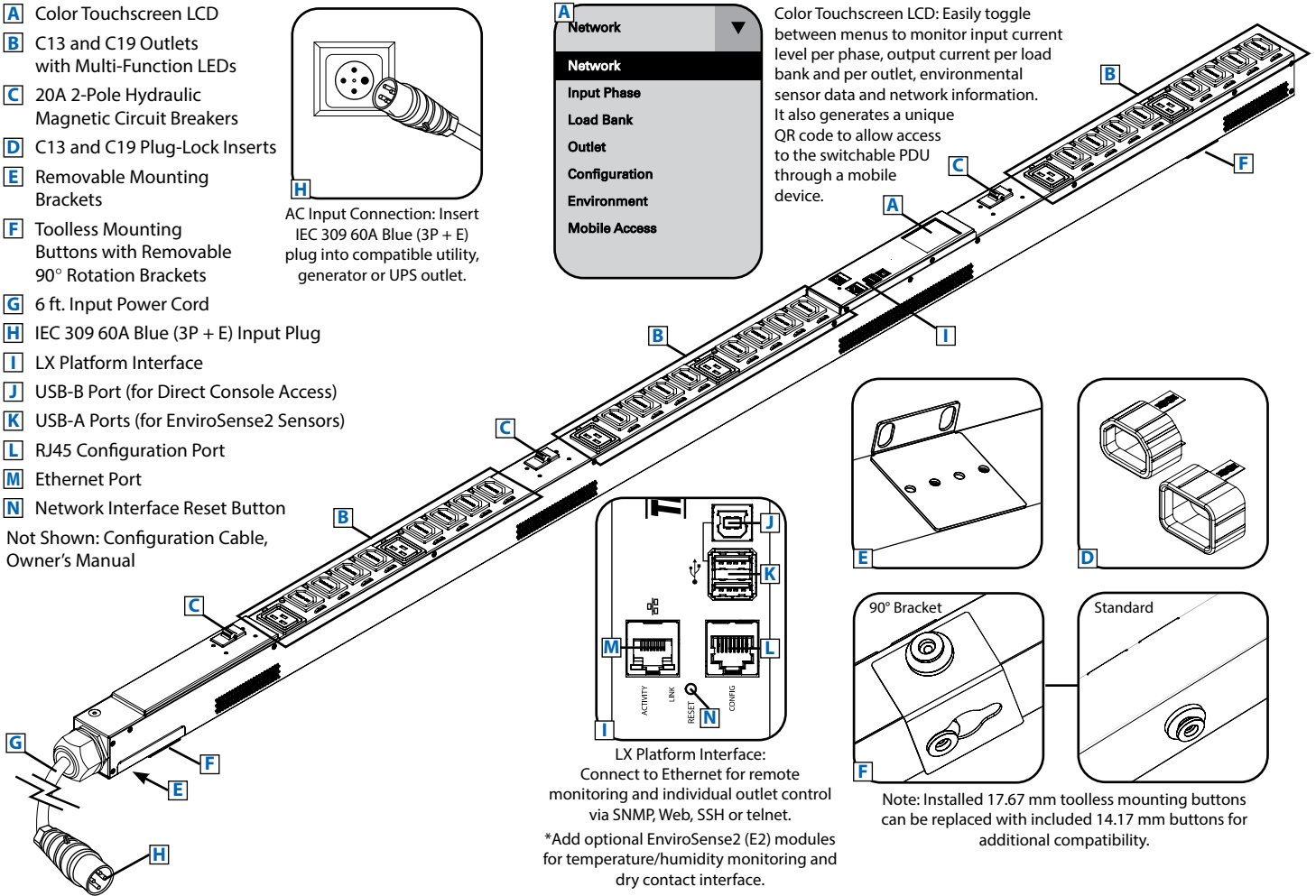

LX Platform Interface: Connect to Ethernet for remote monitoring and individual outlet control via SNMP, Web, SSH or telnet.

*Add optional EnviroSense2 (E2) modules for temperature/humidity monitoring and dry contact interface.

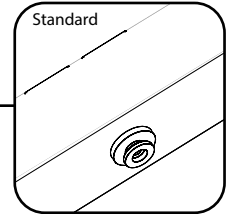
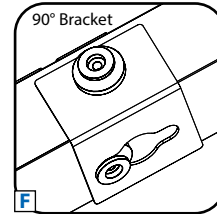
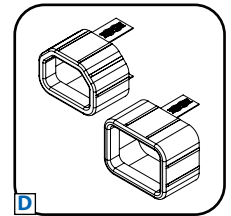
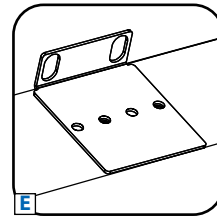

Note: Installed 17.67 mm toolless mounting buttons can be replaced with included 14.17 mm buttons for additional compatibility.

- Distributes power to 30 outlets (8 C13 & 2 C19 per bank)
- Java-free, HTML5-based network interface allows for remote monitoring and control via SNMP, Web, SSH or telnet
- Reports current for each **bank, phase, outlet and total output** in real time with 1% billing grade accuracy
- Perfect for rack-mount server, network and telecom applications

SEE NEXT PAGE FOR DETAILED UNIT MEASUREMENTS



1111 W. 35th Street
Chicago, IL 60609 USA
773.869.1234
www.tripplite.com

Specifications

Model	PDU3EVS6G60
Voltage	200/208/240V (3-Phase Input, Single-Phase Output)
Frequency	50/60 Hz
Load Capacity	8.3kW (200V), 8.6kW (208V), 10kW (240V)
Input Connector	IEC 309 60A Blue (3P + E)
Cord Length	6 ft. / 1.8 m
Outlets	30 (24 C13 / 6 C19)
Primary Mounting Option	0U (Vertical) Rack Mount
Unit Dimensions (H x W x D)	70 x 2.17 x 2.86 in. / 1778 x 551 x 726 mm
Unit Weight	20 lb. / 9 kg
Standards	Tested to UL 60950-1 (US & Canada), NOM (Mexico), FCC Class A; RoHS; TAA



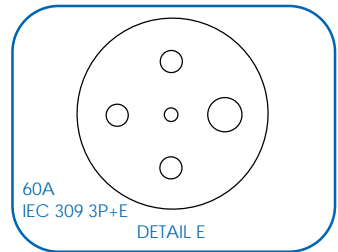
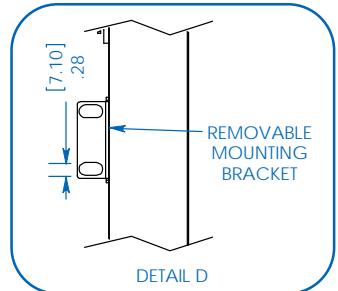
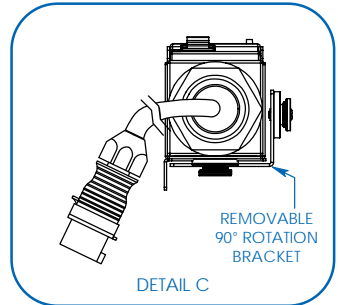
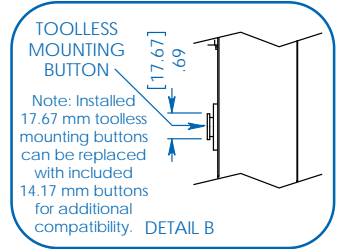
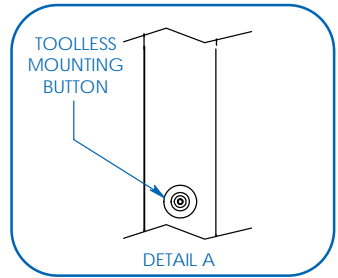
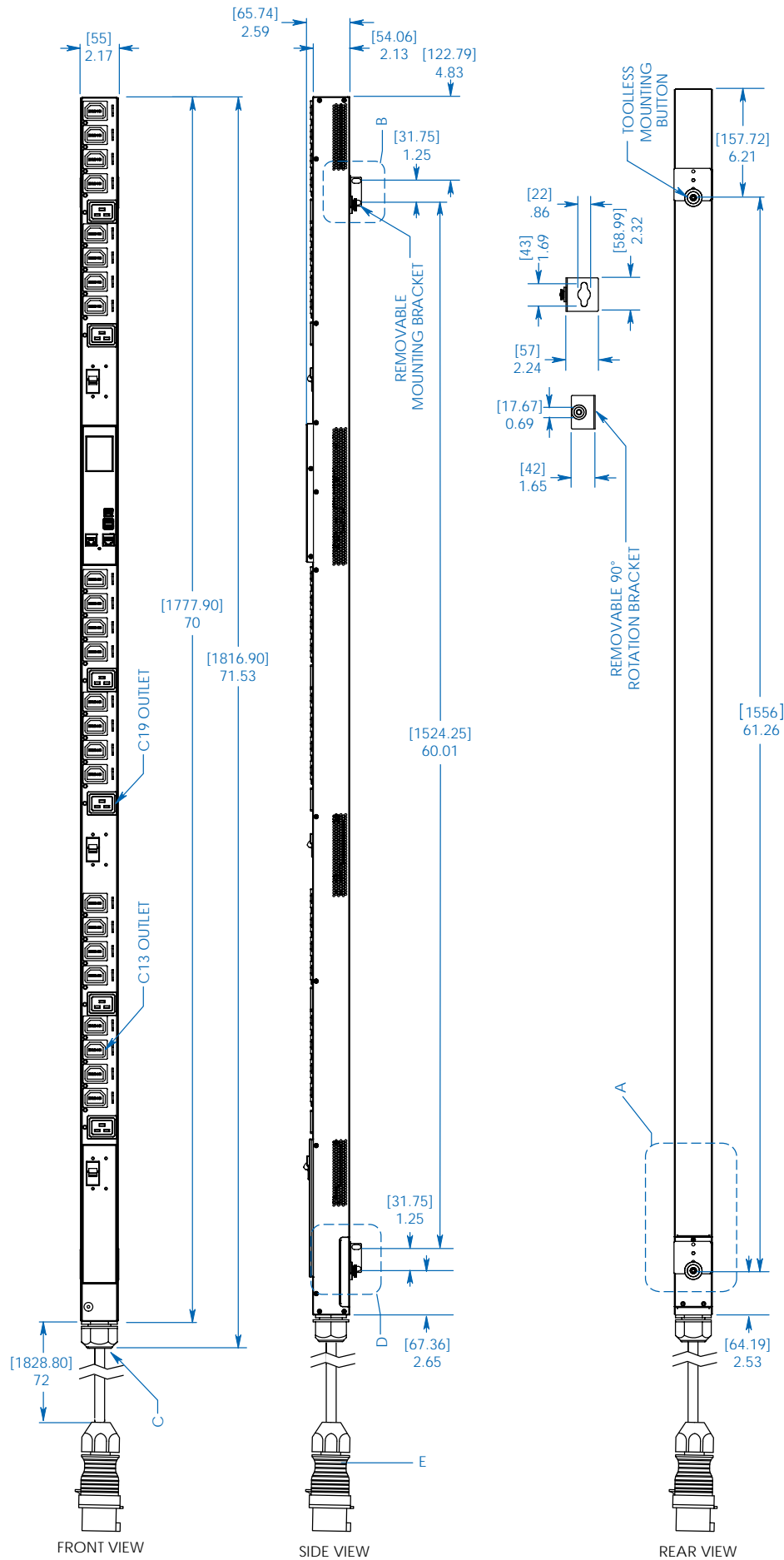

MODEL:
PDU3EVS6G60



1111 W. 35th Street
Chicago, IL 60609 USA
773.869.1234

www.tripplite.com