

MODEL:

CSC21AC

21-Device AC Charging Station Cart



Holds up to 21 Ultrabooks



Laminated Wood-Grain Top



200 lb. Load Rating



Sturdy Steel Construction



Locking Doors

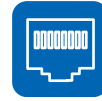

RJ45 Passthrough



Ventilated for Ample Airflow

FRONT VIEW

- A** Laminate Desktop Surface
- B** Reversible Handle
- C** Power Cord Manager
- D** Power Cord Access Hole
- E** 10 ft. Power Cord with 5-15P Plug
- F** Corner Safety Bumpers (6 Total)
- G** Storage Shelves with Dividers
- H** Locking Front Door
- I** Non-Marking Casters (Swivel Casters are Locking)
- J** Cat6 RJ45 Pass Through
- K** Padlock Hasp

REAR VIEW

- L** Power Brick Storage Baskets
- M** AC Power Distribution Unit
- N** Locking Rear Door
- O** Keys

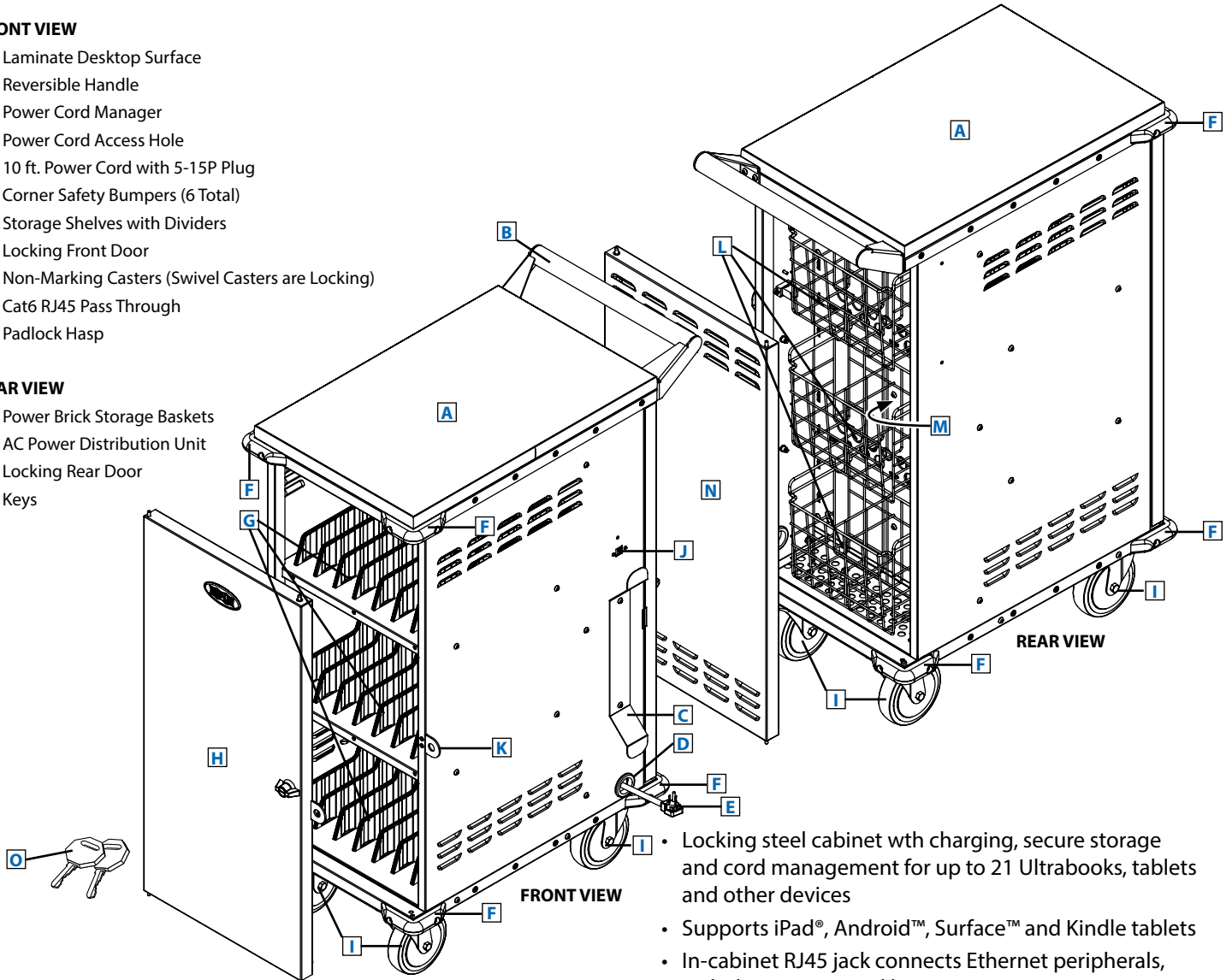

- Locking steel cabinet with charging, secure storage and cord management for up to 21 Ultrabooks, tablets and other devices
- Supports iPad®, Android™, Surface™ and Kindle tablets
- In-cabinet RJ45 jack connects Ethernet peripherals, including routers and hotspots
- Door locks with included keys prevent device theft, damage or tampering

SEE NEXT PAGE FOR DETAILED UNIT MEASUREMENTS

Specifications

Model	CSC21AC
Cabinet Dimensions (H x W x D)	43.3 x 17.6 x 29.6 in. / 1099 x 447 x 751 mm
Unit Weight	116.63 lb. / 52.9 kg
Load Capacity	200 lb. / 90 kg
AC Receptacles	Power Distribution Unit: 27 x 5-15R
Power Requirement	Input: 120V AC, 50/60 Hz, 15 Amps
Operating Temperature	32° to 104° F (0° to 40° C)
Operating Humidity	5 to 95% RH, Non-Condensing



1111 W. 35th Street
 Chicago, IL 60609 USA
 773.869.1234
 www.tripplite.com

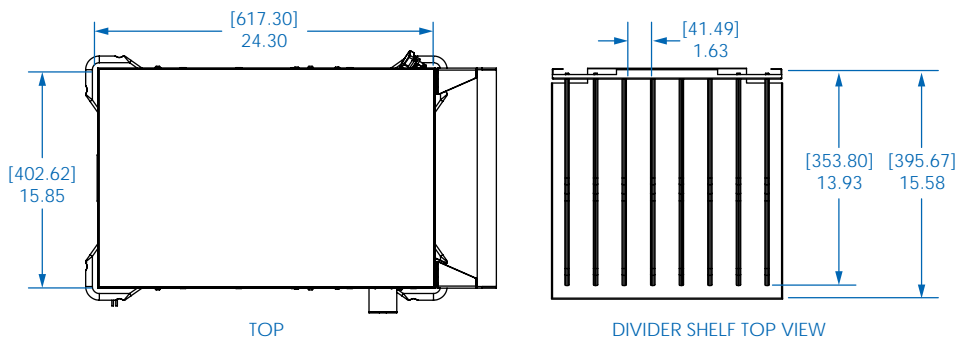
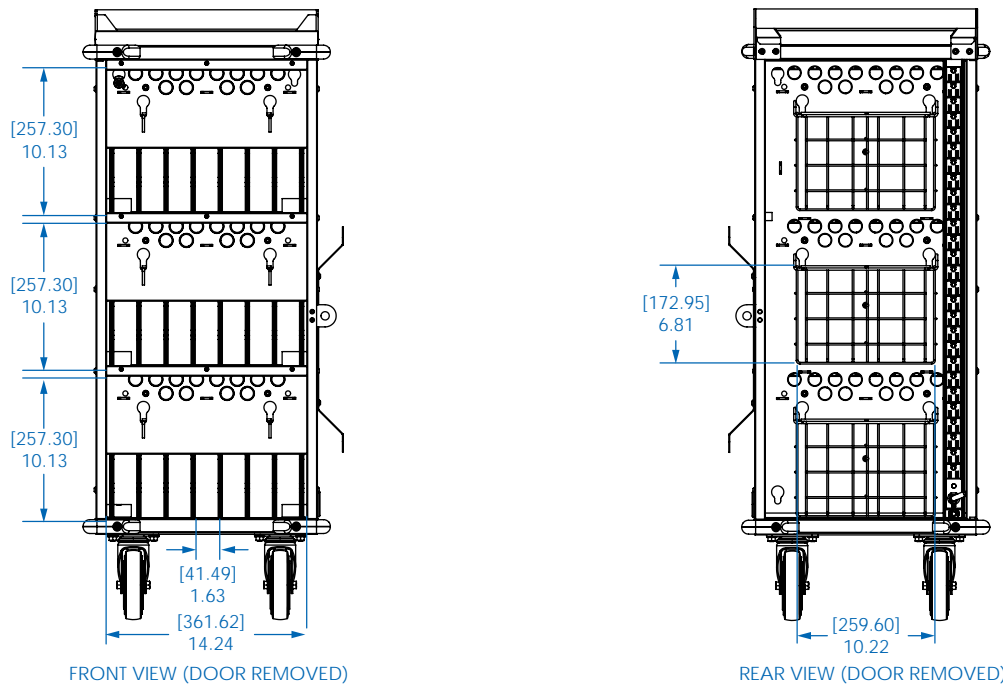
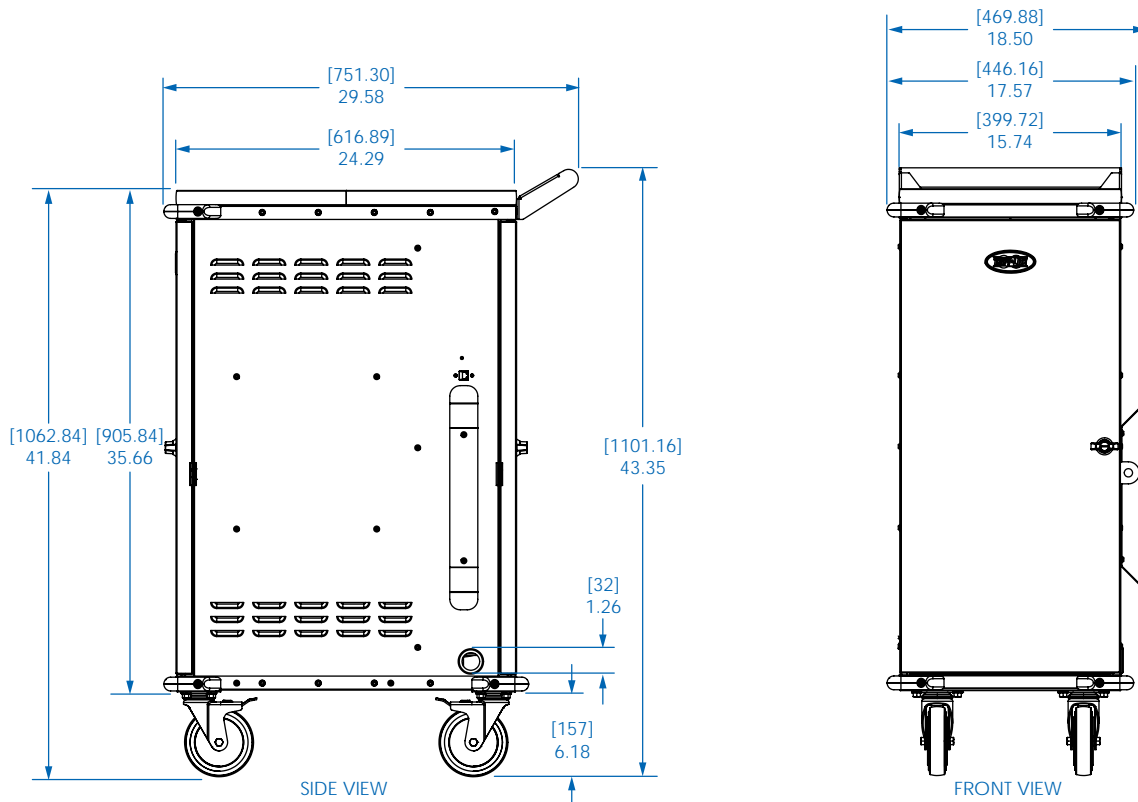

MODEL:
CSC21AC
TRIPP·LITE

1111 W. 35th Street
 Chicago, IL 60609 USA
 773.869.1234
 www.triplite.com

Dimensions: [mm] INCHES

Tripp Lite has a policy of continuous improvement. Specifications are subject to change without notice. Photos and illustrations may differ slightly from actual products.