

MODEL:

4POSTRAILKITWM

4-Post 1U Universal Adjustable Rack-Mount Shelf Kit for Wall-Mount Racks



Mounts in 1U of Space



150 lb.
Load Rating



Sturdy Steel
Construction



14.5 to 23.5 in.
Adjustable Rails

- A** Adjustable-Length Rails
- B** Mounting Brackets

Also Includes: Owner's Manual,
rack- and equipment-mounting hardware
(12 M6 screws, 12 M6 cup washers).

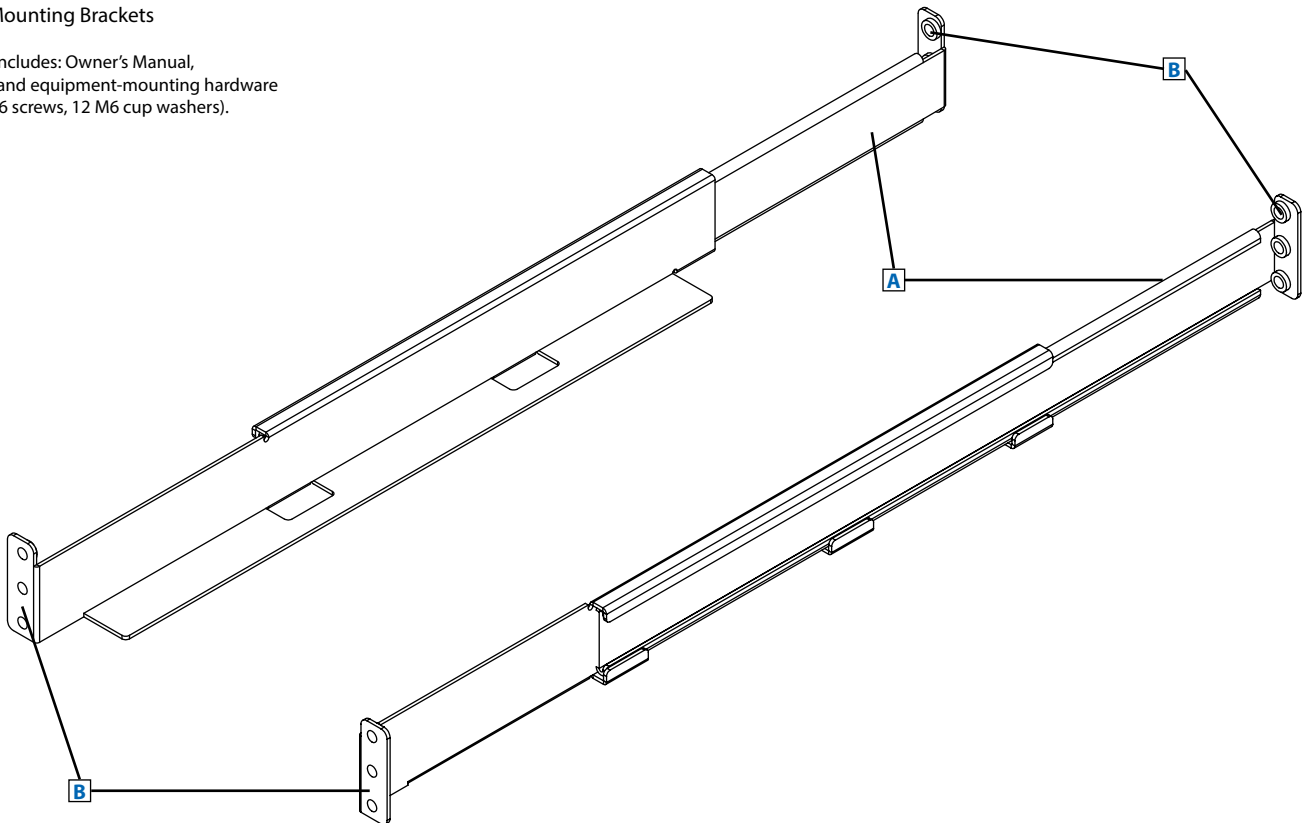

- 1U kit adds an additional rack-mount shelf for a wall-mount rack
- Compatible with 19 in. wall-mount open frame racks and enclosures
- Expandable support rails offer front-to-rear support for equipment with 17.5 in. rectangular chassis

SEE NEXT PAGE FOR DETAILED UNIT MEASUREMENTS

Specifications

Model	4POSTRAILKITWM
Rack Spaces	1U
Load Rating*	150 lb. / 79 kg
Unit Dimensions (H x W x D)**	1.72 x 1.49 x 14.5 - 23.5 in. / 44 x 38 x 368 - 597 mm
Shipping Dimensions (H x W x D)	1.97 x 2.16 x 15.16 in. / 50 x 55 x 385 mm
Unit Weight	2.6 lb. / 1.2 kg
Shipping Weight	3 lb. / 1.4 kg



* The load rating includes the combined weight of the unit and installed equipment. The unit must be mounted to a stable surface with user-supplied anchors capable of bearing the full load.

**Adjustable Equipment Mounting Depth Range



1111 W. 35th Street
Chicago, IL 60609 USA
773.869.1234
www.tripplite.com

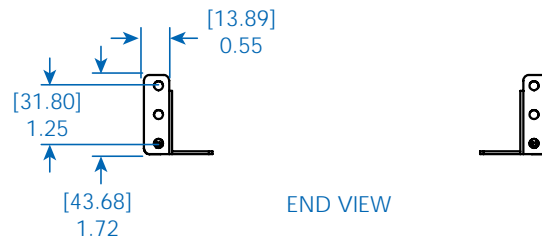
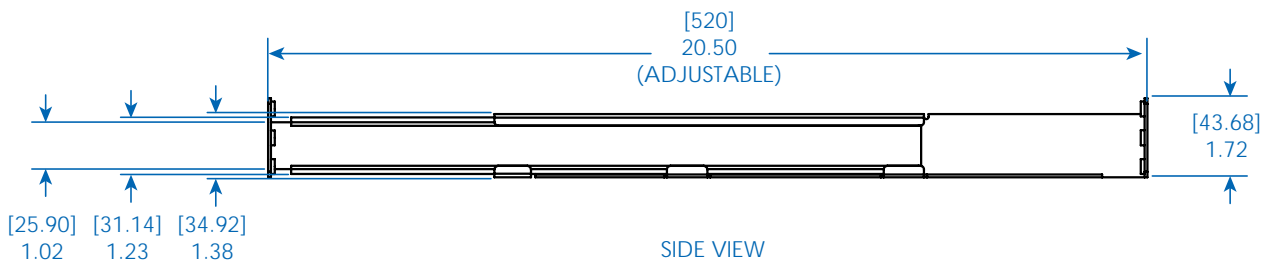
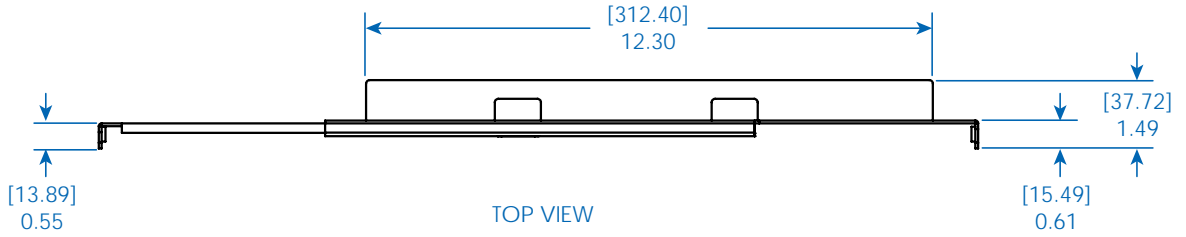
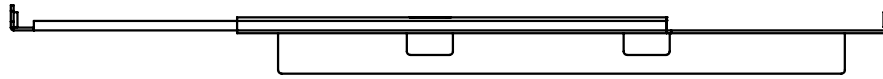

MODEL:
4POSTRAILKITWM



1111 W. 35th Street
Chicago, IL 60609 USA
773.869.1234
www.tripplite.com

Dimensions: [mm] INCHES

Tripp Lite has a policy of continuous improvement. Specifications are subject to change without notice.