

Strengthening Bar Kit for Wire Mesh Cable Trays

MODEL NUMBER: SRWBHDCPLR

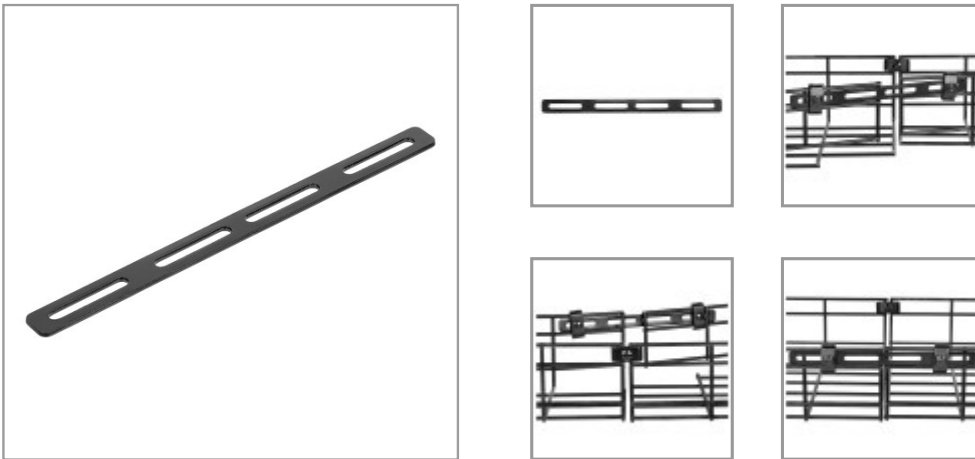

Safely and securely connects straight sections of wire mesh cable tray in your data center, network closet or industrial space.

Features

High-Resiliency Strengthening Bar Helps You Create Custom Cable Management Schemes

The SmartRack® SRWBHDCPLR includes a black powder-coated metal strengthening bar and three couplers, each with an M6 flange nut and M6 x 20 carriage bolt for easy installation with your wire mesh cable tray. This kit allows you to connect two straight sections of cable tray to extend your cable management application along the wall, floor or ceiling of your data center, network closet or industrial space. It is also ideal for creating reductions. The SRWBHDCPLR is compatible with 6-, 12- and 18-inch wire mesh cable trays. For best practice, connecting the tray sections at the bottom with an extra coupler (sold separately) is recommended.

Highlights

- Joins 2 straight sections or creates reductions in your wire mesh cable tray
- Allows you more flexibility in routing custom cable management applications
- Includes 3 couplers, each with a mounting nut and bolt for quick installation

Applications

- Extend a wire mesh cable tray system along the wall, floor or ceiling of your data center
- Strengthen your wire mesh cable tray to provide stability for your cable bundle

System Requirements

SRWB sectional pieces

Package Includes

- Strengthening bar
- (3) Couplers
- (3) M6 flange nuts
- (3) M6 x 20 carriage bolts
- Installation guide

Specifications

OVERVIEW	
UPC Code	037332240378
Product Type	Accessory
Cable Management System Component Type	Accessory
PHYSICAL	
Color	Black



Tripp Lite
1111 W. 35th Street
Chicago, IL 60609 USA
Telephone: 773.869.1234
www.tripplite.com

Shipping Dimensions (hwd / in.)	9.84 x 5.91 x 1.57
Shipping Weight (kg)	0.20
Unit Dimensions (hwd / cm)	1.8 x 24.33 x 0.300
Unit Dimensions (hwd / in.)	0.709 x 9.577 x 0.118
Unit Weight (kg)	0.15
Unit Weight (lbs.)	0.331
WARRANTY	
Product Warranty Period (Worldwide)	5-year limited warranty

© 2020 Tripp Lite. All rights reserved. All product and company names are trademarks or registered trademarks of their respective holders. Use of them does not imply any affiliation with or endorsement by them. Tripp Lite has a policy of continuous improvement. Specifications are subject to change without notice. Tripp Lite uses primary and third-party agencies to test its products for compliance with standards. See a list of Tripp Lite's testing agencies: <https://www.tripplite.com/products/product-certification-agencies>