

Industrial Gigabit Ethernet Switches

Models:
NGI-U08C2
NGI-U05POE4
NGI-U05C2POE4
NGI-U08C2POE8

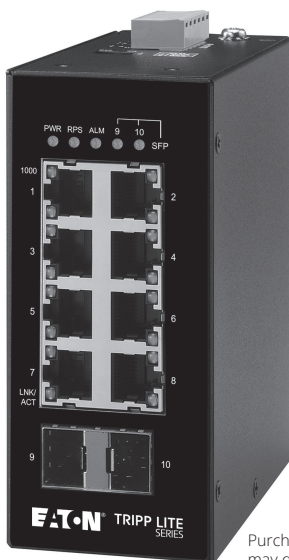

Purchased product
may differ from image.

Este manual está disponible en español en la página de Eaton:
Tripplite.Eaton.com/support

Ce manuel est disponible en français sur le site Web de Eaton :
Tripplite.Eaton.com/support

Dieses Handbuch ist in deutscher Sprache auf der Eaton-Website verfügbar:
Tripplite.Eaton.com/support

Questo manuale è disponibile in italiano sul sito web di Eaton:
Tripplite.Eaton.com/support

EATON

Powering Business Worldwide

Package Contents

- NGI-U08C2 (non-PoE), NGI-U05POE4, NGI-U05C2POE4 or NGI-U08C2POE8 Plug-and-Play Gigabit PoE Ethernet Switch
- DIN-rail mounting clip (pre-installed on unit)
- Owner's Manual

Product Features

- 5 or 8 10/100/1000Mbps RJ45 ports with PoE/PoE+ (NGI-U08C2 is a non-PoE switch)
- Each PoE port provides up to 30W
 - o Total PoE power budget of 120W (NGI-U05C2POE4 and NGI-U05POE4 models)
Power budget of 240W when input voltage is 48VDC or 120W when input voltage is 24VDC
- 10/100/1000, Full/Half Duplex, Auto MDI/MDIX cross-over function
- Plug and Play—no configuration required
- EIP/QoS functionality
- Flow and storm control
- Rugged high-strength metal case
- Industrial temperature switch models support operating temperature range of -40°F to 167°F (-40°C to 75°C)
- Easy to read LEDs indicate connection and activity status for each port

Product Features

- Meets the following IEEE standards:
 - o IEEE 802.3 10Base-T
 - o IEEE 802.3u 100Base-T
 - o IEEE 802.3ab 1000Base-T
 - o IEEE 802.3 Auto Negotiation
 - o IEEE 802.3z 1000Base-SX/LX
 - o IEEE 802.1p Class of Service (NGI-U08C2 and NGI-U08C2POE8 Models Only)
 - o IEEE 802.3az EEE (NGI-U08C2POE8 Only)
 - o IEEE 802.3af PoE
 - o IEEE 802.3at PoE+
- Supports MAC address auto-learning and auto-aging
- Pre-installed durable rail clip mounts firmly to any standard 35 mm DIN Rail
- User-configurable DIP switches for alarms (NGI-U08C2POE8 Only)

Optional Accessories

- N001-Series Cat5e 350 MHz Snagless UTP Cables
- N002-Series Cat5e 350 MHz UTP Ethernet Cables
- N200-Series Cat6 Gigabit Molded UTP Ethernet Cables
- N201-Series Cat6 Gigabit Snagless Molded UTP Ethernet Cables
- N320-Series Duplex Multimode 62.5/125 Fiber Patch Cables
- N520-Series Duplex Multimode 50/125 Fiber Patch Cables
- N820-Series Duplex Multimode 50/125 OM3 LSZH Fiber Patch Cables
- N286I-1P25GLXD1 Industrial Gigabit SFP Transceiver, 1000LX 1.25G
- N286I-1P25GSXD Industrial Gigabit SFP Transceiver, 1000SX 1.25G

Product Overview

NGI-U08C2 (non-PoE)

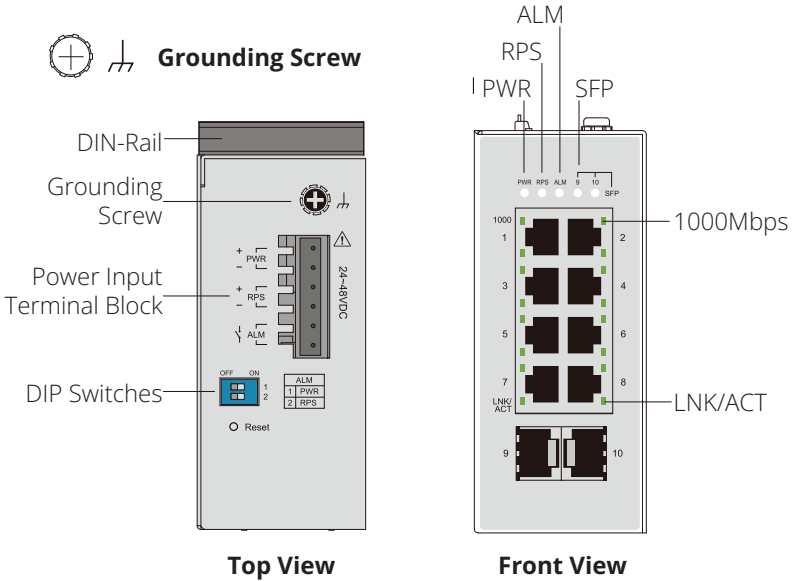

NGI-U05POE4

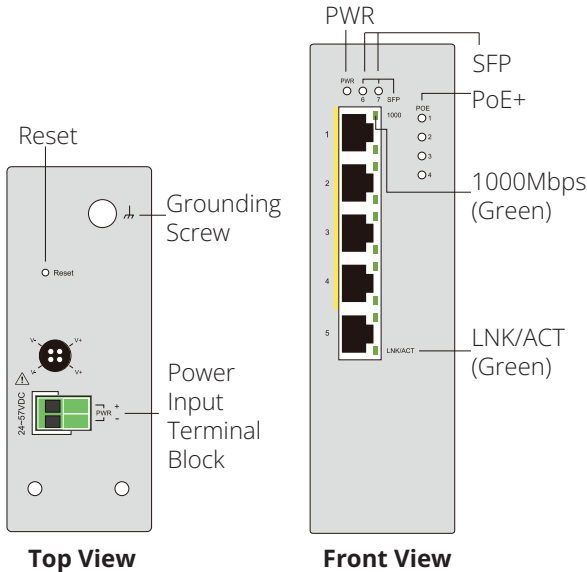

Product Overview

NGI-U05C2POE4

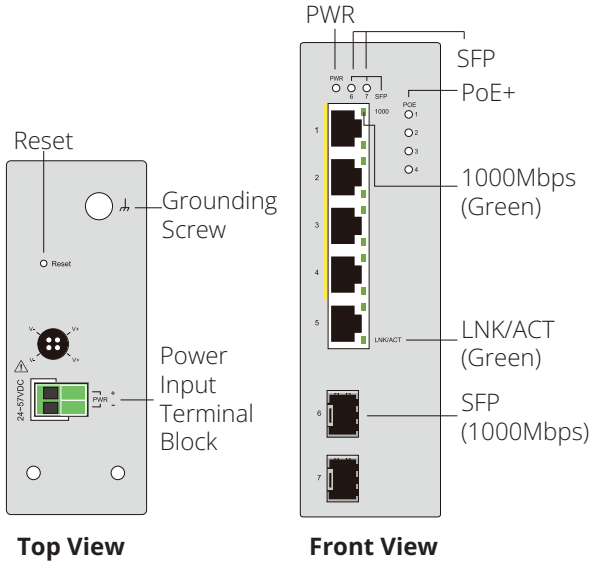

NGI-U08C2POE8

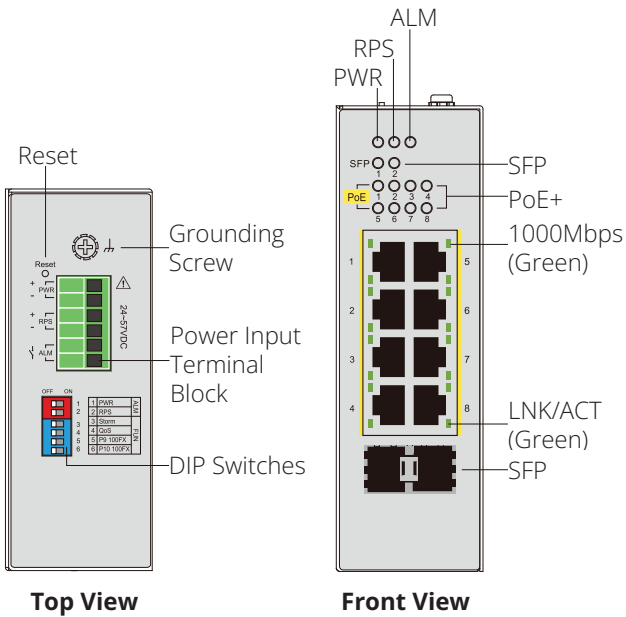

Mounting and Dismounting to DIN-Rail

Mounting the Switch

Place the Gigabit Ethernet PoE+ switches or NGI-U08C2 switch on the DIN rail from above using the slot, then push the front of the switch toward the mounting surface until it snaps into place with a click sound.

Dismounting the Switch

Press the switch from top and pull out the lower edge of the switch, then remove the switch from the DIN rail.

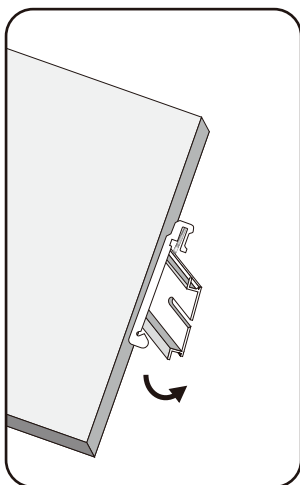

Mounting the Switch

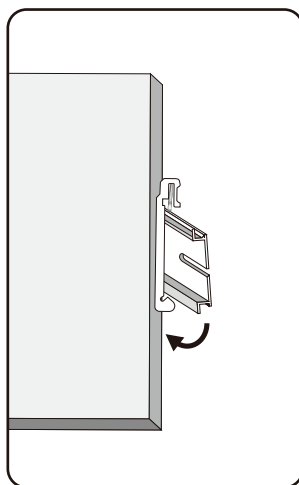

Removing the Switch



ATTENTION: Use of a corrosion-free mounting rail is advisable. When installing, make sure to allow enough space to properly install the cabling and allow ample airflow.

Mounting and Dismounting to DIN-Rail

Wiring Requirements



WARNING: Safety measures should be taken before connecting the power cable. Turn off the power before connecting modules or wires. The correct power supply voltage is listed on the product label. Check the voltage of your power source to make sure you are using the correct voltage. **DO NOT** use a voltage greater than what is specified on the product label. Calculate the maximum possible current in each power wire and common wire. Observe all electrical codes dictating the maximum current allowable for each wire size. If current exceeds the maximum rating, the wiring can overheat causing serious damage to your equipment.

Please read and follow these guidelines:

- Use separate paths to route wiring for power and devices. If power wiring and device wiring paths must cross, make sure the wires are perpendicular at the intersection point.

Note: Do not run signal or communications wiring and power wiring through the same wire conduit. To avoid interference, wires with different signal characteristics should be routed separately.

- You can use the type of signal transmitted through a wire to determine which wires should be kept separate. A general rule is that wiring that shares similar electrical characteristics can be bundled together.
- Always separate input wiring from output wiring.
- Labelling the wiring to all devices in the system is advised.

Mounting and Dismounting to DIN-Rail

Power Input

Safety measures should be taken before connecting the power cable. Turn off the power before connecting modules or wires. The correct power supply voltage is listed on the product label. Check the voltage of your power source to make sure you are using the correct voltage. DO NOT use a voltage greater than what is specified on the product label. Calculate the maximum possible current in each power wire and common wire. Observe all electrical codes dictating the maximum current allowable for each wire size. If current exceeds the maximum rating, the wiring can overheat causing serious damage to your equipment.



CAUTION: The surface of the power output may be hot, do not touch. Wear protective equipment before making contact.

Wiring Power Input

NGI-U08C2 with 6-Pin Terminal Block

Use “PWR” for Primary Power input and “RPS” for Redundant Power input. The top view of Terminal Block is shown in the figure below:

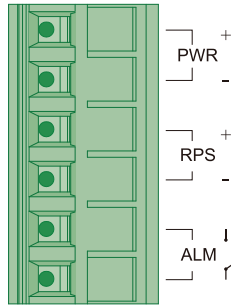

Terminal Block



Caution:

- Use copper conductors only.
- Use wiring cable with rated temperature at least 221°F (105°C).
- Tighten the wire to a torque value 4.5 lb•in (0.5 N•m).
- The wire gauge for the terminal block should range between 12~24 AWG (4~0.25 mm²).

To insert the power wire and connect the 24~48VDC at a maximum of 0.4A DC power to the power terminal block:

- Use a flathead screwdriver to loosen the wire clamp screws.
- Insert the negative/positive DC wires into the PWR-/PWR+ terminals, respectively.
- Tighten the wire-clamp screws to prevent the wires from loosening.



ATTENTION: Use a power supply rated for 24~48VDC. The device power must be supplied by SELV circuit.

Wiring Power Input

Wiring the Relay Contact (ALM)

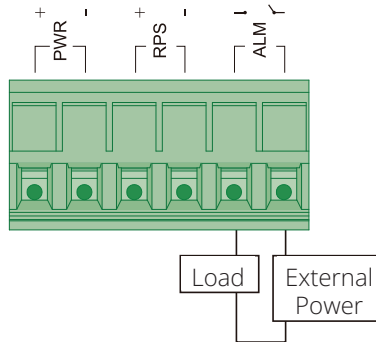

Relay rating: 24V, 1A

The NGI-U08C2 has one set of relay alarm output. This relay contact uses two contacts of the terminal block on the top panel. The two contacts of the 6-pin terminal block connector are used to detect user-configured events. The two wires attached to the fault contacts form an open circuit when a user-configured event is triggered. If a user-configured event does not occur, the fault circuit remains closed.

DIP Switch Settings

The switch supports an Alarm Relay Output function where you can connect an alarm light or a buzzer. When events occur enabled by the DIPs, the switch will operate the relay ON to enable the alarm light or buzzer. The load can be an alarm light, a buzzer or other equipment.

Wiring Power Input

User-Configurable Switches

PWR or RPS “DIP ON”: When there is a power loss, the switch will operate as “Relay ON”. If connecting only to single power source and a power loss occurs, the switch system will shut down and not operate as “Relay ON”.

Port 1~ Port X: “DIP ON”: If the port link is down, the switch will operate as “Relay ON”. In doing so, it can help to inform when link-down events occur.

It is not required to connect alarm equipment to the Alarm Relay output port. An ALARM LED indicator is located on the front panel.

Default settings for the DIP switch are set to OFF positions.

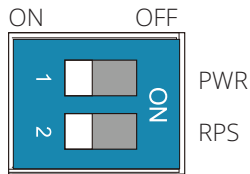

	DIP Position	Description
PWR	ON	Primary power alarm reporting is enabled.
	OFF	Primary power alarm reporting is disabled.
RPS	ON	Redundant power alarm reporting is enabled.
	OFF	Redundant power alarm reporting is disabled.

Wiring Power Input

Redundant Power Input (NGI-U08C2POE8 Only)

Use "PWR" for Primary Power input and "RPS" for Redundant Power input.
To insert the power wire and connect the +24~57VDC power to the power terminal block:

- Use a flathead screwdriver to loosen the wire clamp screws.
- Insert the corresponding wires into the contacts.
- Tighten the wire clamp screws to prevent the wires from loosening.

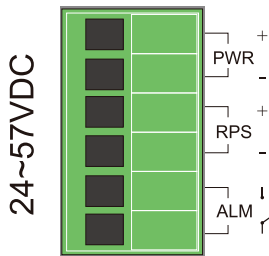

**Top View of the
Terminal Block**

Wiring Power Input

DIP Switch Settings and Reset Button

	DIP Position	Description
PWR	ON	Primary power alarm reporting is enabled.
	OFF	Primary power alarm reporting is disabled.
RPS	ON	Redundant power alarm reporting is enabled.
	OFF	Redundant power alarm reporting is disabled.
Storm	ON	Broadcast/DLF storm control is enabled.
	OFF	Broadcast/DLF storm control is disabled.
QoS	ON	Port-based QoS enabled on P1 & P2.
	OFF	802.1p QoS enabled (default).
P9 100FX	ON	Port 9 link speed is set to 100Base-FX.
	OFF	Port 9 link speed is set to 1000Base-SX/LX.
P10 100FX	ON	Port 10 link speed is set to 100Base-FX.
	OFF	Port 10 link speed is set to 1000Base-SX/LX.

Reset Button: Press the button for a hardware reset (initialization). Refer to “Top View of the Terminal Block” diagram for button location.

Note: The reset button function is only for hardware reset, it does not affect any setting because the switch model does not require software.

Wiring Power Input

The first two relate to alarm design:

- **PWR/RPS**

The switch supports dual power input, we define these power source as Primary Power Supplier (PWR) and Redundant Power Supplier (RPS). These two DIP switches are designed to provide an alarm mechanical to monitor the power connective status. If DIP switch is set to ON means alarm function is enabled.

The remaining four relate to functionality:

- **Storm**

Storm control is used to prevent the local area network (LAN) from being disrupted by broadcast or destination lookup failure (DLF) storm. The storm occurs when broadcast or DLF packets are generated and flood into the LAN, this excessive traffic degrades network performance. If the DP switch is set to ON, it means system will measure broadcast and DLF packets and suppress them if the threshold is reached.

- **QoS**

The switch supports two types of QoS, Port-based QoS (Port Priority) and VLAN Tag-based QoS (802.1p). Port priority is only enabled on port 1 and port 2 which ingress packets will be handle with high transmission priority. If VLAN packets with pre-defined priority are coming into switch (any port), system will refer to it's specified priority for transmission.

- **Fiber Speed – P9 and P10**

For legacy operation, there is a dual-speed support (100BASE-FX / 1000BASE-SX/LX) on switch fiber ports. Depending on the network environment, a user can choose the proper SFP transceiver and set the related DIP switch for fiber connectivity.

Wiring Power Input

Wiring Power Input (NGI-U05C2POE4 and NGI-U05POE4 Models Only)

You can use “PWR” from the terminal block or 4-pin Mini-DIN for Power input.

Top view of connectors are shown below:

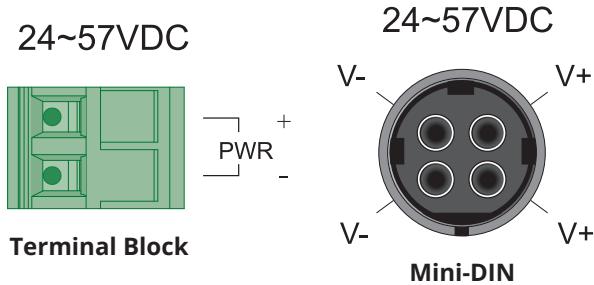

Caution:

- Use copper conductors only.
- Use wiring cable with rated temperature at least 221°F (105°C).
- Tighten the wire to a torque value 4.5 lb·in (0.5 N·m).
- The wire gauge for the terminal block should range between 12~18 AWG (4~0.75 mm²).

Connecting to Terminal Block

To insert the power wire and connect the +24~57VDC at a maximum of 6A DC power to the power terminal block:

- Use a flathead screwdriver to loosen the wire clamp screws.
- Insert the negative/positive DC wires into the PWR-/PWR+ terminals, respectively.
- Tighten the wire clamp screws to prevent the wires from loosening.

Wiring Power Input

Connecting to the 4-Pin Mini DIN Connector

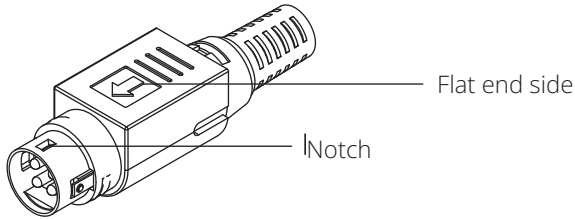

- Face the flat end to the right side of the switch and insert into the female 4-pin receiver.

Note: Make sure the notch is securely inserted properly into female receiver.

- While removing, pull the connector upwards to release the lock and take it out.



**ATTENTION: Use a power supply rated for 24~48VDC.
The device power must be supplied by SELV circuit.**

RJ45 Cabling

Connect one end of an Ethernet/RJ45 cable into the Ethernet port of the switch and the other end to the attached networking device.

- Ports 1-4 of the switch support Fast Ethernet in addition to Gigabit Ethernet 10/100/1000Base-T PSE Ports (NGI-U05POE4/NGI-U05C2POE4 models only).
- Ports 1-8 of the switch support Fast Ethernet in addition to Gigabit Ethernet 10/100/1000Base-T (NGI-U08C2/POE models only).
- Port 5 of the switch supports Fast Ethernet in addition Gigabit Ethernet 10/100/1000Base-T RJ45 Port (NGI-U05POE4/NGI-U05C2POE4 models only).
- Ports 6-7 of the NGI-U05C2POE4 support only Gigabit speed SFP Slots.
- All RJ45 ports on the Gigabit Ethernet PoE+ and non-PoE switches support Auto Negotiation and Auto MDI/MDI-X to eliminate the need for crossover cabling.

Note: Category 5e cable, Cat6 or above should be used.

Wiring Power Input

Grounding the NGI-Series Switches

Grounding and wire routing help to limit the effects of noise due to electromagnetic interference (EMI). Run the ground connection from the ground screw to the grounding surface prior to connecting devices.



ATTENTION: This product is intended to be mounted to a well-grounded mounting surface (such as a metal panel).

LED Indicators

NGI-U08C2 (Non-PoE)

LED (Color)	Status	Description
PWR (Green)	Illuminated	Primary power is supplied to the switch.
	Off	Primary power off or failure.
RPS (Green)	Illuminated	Redundant power is supplied to the switch.
	Off	Redundant power off or failure.
ALM (Red)	Illuminated	External signal device will be activated through the terminal block ALM when there is any alarm. Alarm for following conditions: <ul style="list-style-type: none">• Power lost (primary or secondary).• Abnormal voltage input.
	Off	No alarm to report.
SFP 9~10 (Green)	Illuminated	SFP port link-up.
	Blinking	Activity (receiving or transmitting data).
	Off	Port disconnected or link failed.
1000 (Green)	Illuminated	Port is operating in 1000Mbps speed.
	Off	Port is operating in 10/100Mbps speed.
LNK/ACT (Green)	Illuminated	Ethernet link up.
	Blinking	Activity (receiving or transmitting data).
	Off	Port disconnected or link failed.

LED Indicators

NGI-U05C2POE4 and NGI-U05POE4

LED (Color)	Status	Description
PWR (Green)	Illuminated	Power On by terminal block PWR or 4-pin mini DIN connector.
	Off	Terminal block PWR/4-pin mini DIN connector is not available.
POE 1-4 (Green)	Illuminated	Supplying power to PD devices.
	Off	No power supplied to PD devices.
1000 (Mbps)	Illuminated	Copper ports communicate at 1000Mbps speed.
	Off	Copper ports communicate at 10/100Mbps speed.
LNK/ACT (Green)	Illuminated	Ethernet link is up.
	Blinking	Activity (receiving or transmitting data).
	Off	Port disconnected or link failed.
SFP NGI-U05C2POE4 (Green)	Illuminated	Data is transmitting / receiving.
	Off	Port disconnected or link failed.

LED Indicators

NGI-U08C2POE8

LED (Color)	Status	Description
PWR (Green)	Illuminated	Primary Power is connected.
	Off	Primary Power failure or not available.
RPS (Green)	Illuminated	Redundant Power is connected.
	Off	Redundant Power failure or not available.
ALM (Red)	Illuminated	Alarm for no Primary power or Low I/P voltage.
	Off	No alarm to report or DIP function is disabled.
PoE 1-8 Ports (Green)	Illuminated	PoE power is delivered to the powered device (PD).
	Off	PoE power feeding is not functioning.
1000 (Green)	Illuminated	Link on 1000Mbps.
	Off	Link on 100Mbps or 10Mbps.
LNK/ACT (Green)	Illuminated	Ethernet link is up.
	Blinking	Activity (receiving or transmitting data).
	Off	Port disconnected or link failed.
SFP (Green)	Illuminated	Data is transmitting / receiving.
	Off	Port disconnected or link failed.

Specifications

Model	NGI-U08C2 (Non-PoE)	NGI-U05C2POE4	NGI-U05POE4	NGI-U08C2POE8
Power				
Input Voltage	Dual power inputs 24~48VDC/0.4A	Single power input 24~57VDC/6A	Single power input 24~57VDC/6A	Dual power inputs 24~57VDC/6A
Connection	6-pin terminal block	2-pin terminal block	2-pin terminal block	6-pin terminal block
Reverse Polarity Protection	Present	Present	Present	Present
Power Consumption (System Only)	11W	14W	13W	14W
Grounding Screw	Present	Present	Present	Present
PoE (Per Port)	No	30W	30W	30W
PoE Power Budget	No	120W	120W	120W@24VDC 240W@48VDC
Interface				
Rj45	8 x 10/1001000Base-T copper ports support Auto- Negotiation, Auto MDI/MDI-X, Full/Half Duplex and Flow Control.	4 x 10/1001000Base-T PoE+, 1 x 10/1001000Base-T copper ports support Auto- Negotiation, Auto MDI/MDI-X, Full/Half Duplex and Flow Control. Four copper ports support PoE/PoE+.	4 x 10/1001000Base-T PoE+, 1 x 10/1001000Base-T copper ports support Auto- Negotiation, Auto MDI/MDI-X, Full/Half Duplex and Flow Control. Four copper ports support PoE/PoE+.	8 x 10/1001000Base-T PoE+ copper ports support Auto- Negotiation, Auto MDI/MDI-X, Full/Half Duplex and Flow Control. Eight copper ports support PoE/PoE+.
Fiber Ports	2x 1000Base-X SFP slots	2x 1000Base-X SFP slots	-	2x 1000Base-X SFP slots
LED Indicators	PWR (Green): Power by terminal block PWR RPS (Green): Power by terminal block RPS ALM (Red): PWR and RPS fails SFP 9~10 (Green): Port 9~10 SFP link-up 1000 (Green): Port 1~8 Ethernet speed 1000Mbps LNK/ACT (Green): Data Transmitting/ Receiving	PWR (Green): Power PoE 1~4 (Green): Supplying power to PD device SFP 6~7 (Green): Port 6~7 SFP link-up 1000 (Green): Port 1~5 Ethernet speed 1000Mbps LNK/ACT (Green): Data Transmitting/ Receiving	PWR (Green): Power PoE 1~4 (Green): Supplying power to PD device 1000 (Green): Port 1~5 Ethernet speed 1000Mbps LNK/ACT (Green): Data Transmitting/ Receiving	PWR (Green): Power by terminal block PWR RPS (Green): Power by terminal block RPS ALM (Red): PWR and RPS fails PoE 1~8 (Green): Supplying power to PD device 1000 (Green): Port 1~8 Ethernet speed 1000Mbps SFP 9~10 (Green): Port 9~10 SFP link-up LNK/ACT (Green): Data Transmitting/ Receiving
Alarm Relay Output	1 alarm relay output for power loss	-	-	1 alarm relay output for power loss

Specifications

Model	NGI-U08C2 (Non-PoE)	NGI-U05C2POE4	NGI-U05POE4	NGI-U08C2POE8
Environmental				
Operating Temperature	-40°F~167°F (-40°C~75°C)	14°F~140°F (-10°C~60°C)	14°F~140°F (-10°C~60°C)	-40°F~167°F (-40°C~75°C)
Storage Temperature	-40°F~185°F (-40°C~85°C)	-40°F~185°F (-40°C~85°C)	-40°F~185°F (-40°C~85°C)	-40°F~185°F (-40°C~85°C)
Operating Humidity	5 to 95% RH (non-condensing)	5 to 95% RH (non-condensing)	5 to 95% RH (non-condensing)	5 to 95% RH (non-condensing)
Storage Humidity	5 to 95% RH (non-condensing)	5 to 95% RH (non-condensing)	5 to 95% RH (non-condensing)	5 to 95% RH (non-condensing)
Operating Altitude	6561 ft. (2000 m)	6561 ft. (2000 m)	6561 ft. (2000 m)	6561 ft. (2000 m)
Regulatory Approvals				
EMI/EMC	FCC Part 15 EN 55011 EN 61000-6-4 EN 61000-6-2 EN 55032 EN 55024	FCC Part 15 EN 55011 EN 61000-6-4 EN 61000-6-2 EN 55032 EN 55024	FCC Part 15 EN 55011 EN 61000-6-4 EN 61000-6-2 EN 55032 EN 55024	FCC Part 15 EN 55011 EN 61000-6-4 EN 61000-6-2 EN 55032 EN 55024

ATTENTION: If the switch is used in a manner not specified here, the protection provided by the switch may be impaired.

Warranty

3-Year Limited Warranty

We warrant our products to be free from defects in materials and workmanship for a period of three (3) years from the date of initial purchase. Our obligation under this warranty is limited to repairing or replacing (at its sole option) any such defective products. Visit Triplite.Eaton.com/support/product-returns before sending any equipment back for repair. This warranty does not apply to equipment which has been damaged by accident, negligence or misapplication or has been altered or modified in any way.

EXCEPT AS PROVIDED HEREIN, WE MAKE NO WARRANTIES, EXPRESS OR IMPLIED, INCLUDING WARRANTIES OF MERCHANTABILITY AND FITNESS FOR A PARTICULAR PURPOSE. Some states do not permit limitation or exclusion of implied warranties; therefore, the aforesaid limitation(s) or exclusion(s) may not apply to the purchaser.

EXCEPT AS PROVIDED ABOVE, IN NO EVENT WILL WE BE LIABLE FOR DIRECT, INDIRECT, SPECIAL, INCIDENTAL OR CONSEQUENTIAL DAMAGES ARISING OUT OF THE USE OF THIS PRODUCT, EVEN IF ADVISED OF THE POSSIBILITY OF SUCH DAMAGE. Specifically, we are not liable for any costs, such as lost profits or revenue, loss of equipment, loss of use of equipment, loss of software, loss of data, costs of substitutes, claims by third parties, or otherwise.

FCC Notice, Class B

This device complies with part 15 of the FCC Rules. Operation is subject to the following two conditions: (1) This device may not cause harmful interference, and (2) this device must accept any interference received, including interference that may cause undesired operation.

Note: This equipment has been tested and found to comply with the limits for a Class B digital device, pursuant to part 15 of the FCC Rules. These limits are designed to provide reasonable protection against harmful interference in a residential installation. This equipment generates, uses and can radiate radio frequency energy and, if not installed and used in accordance with the instructions, may cause harmful interference to radio communications. However, there is no guarantee that interference will not occur in a particular installation. If this equipment does cause harmful interference to radio or television reception, which can be determined by turning the equipment off and on, the user is encouraged to try to correct the interference by one or more of the following measures:

- Reorient or relocate the receiving antenna.
- Increase the separation between the equipment and receiver.
- Connect the equipment into an outlet on a circuit different from that to which the receiver is connected.
- Consult the dealer or an experienced radio/TV technician for help.

Any changes or modifications to this equipment not expressly approved by Eaton could void the user's authority to operate this equipment.

Warranty

WEEE Compliance Information for Customers and Recyclers (European Union)



Under the Waste Electrical and Electronic Equipment (WEEE) Directive and implementing regulations, when customers buy new electrical and electronic equipment from Eaton, they are entitled to:

- Send old equipment for recycling on a one-for-one, like-for-like basis (this varies depending on the country)
- Send the new equipment back for recycling when this ultimately becomes waste

Use of this equipment in life support applications where failure of this equipment can reasonably be expected to cause the failure of the life support equipment or to significantly affect its safety or effectiveness is not recommended.

Eaton has a policy of continuous improvement. Specifications are subject to change without notice. Photos and illustrations may differ slightly from actual products.



Eaton
1000 Eaton Boulevard
Cleveland, OH 44122
United States
Eaton.com

© 2023 Eaton
All Rights Reserved
Publication No. 23-08-386 / 93-3E8B_RevB
September 2023



933E8B

Eaton is a registered trademark.

All trademarks are property
of their respective owners.