



Height-Adjustable Wall Mounts

Powering and Connecting Your World

Make Touchscreens More Accessible



Easily raise and lower height-adjustable wall mounts to accommodate users of all sizes.

Perfect for:

Mounting interactive displays and other large flat-panel displays in schools, conference rooms and any pro AV installation.

Promote more interaction with interactive displays with Tripp Lite's new height-adjustable display wall mounts. These sturdy steel mounts are strong enough to handle heavy whiteboards and other interactive displays, while their innovative counterbalance technology provides simple one-touch vertical display adjustment.

These two VESA-compliant mounts are compatible with most display brands and are easy to install. As a solution that is purpose-built for touchscreens, they help maximize engagement for a variety of users in a variety of environments.

Key Benefits

BROAD COMPATIBILITY WITH LARGE INTERACTIVE DISPLAYS

- Mounts can accommodate televisions, digital whiteboards and interactive displays up to 90 in. and 198 lb. (size limits vary by model).
- VESA-compliant mounting brackets provide hassle-free display installation.

EASE OF VERTICAL ADJUSTMENT

- Counterbalanced springs allow the mounted display to glide up and down the wall with the touch of a finger.
- Mounts have a 15.7 in. vertical adjustment range for optimal viewing angles and to accommodate the reach of different interactive users.

DURABLE CONSTRUCTION

- Mounts are made of heavy-duty steel for durability.
- Black powder-coated finish resists scratches.

CONVENIENT SETUP AND ADJUSTMENT

- Hardware is included for mounting on a wood, brick or concrete wall surface.
- Height-adjustment capabilities.

Feature Focus

A Counterbalanced Springs

Intricately designed counterbalanced springs allow a connected display to glide up and down with a simple touch—no electric power required.

B VESA-Compliant Brackets

The brackets adhere to VESA (Video Electronics Standards Association) uniformity standards for hassle-free display compatibility.

C Height Adjustment Track

15.7-in. height adjustment puts displays in reach of touchscreen users of all sizes.

D Balance Bolts

Four balance bolts can adjust the mount's balance setting to custom-fit the weight of a display.

E Steel Construction

The mounts can accommodate interactive displays up to 132 lb. (DWM5070HD) or 198 lb. (DWM7090HD).

Powder Coat Finish

A black powder-coated finish resists scratches for a long-lasting professional appearance.

Assembly Hardware

All the nuts, bolts, washers and other hardware required to install the mount comes included.

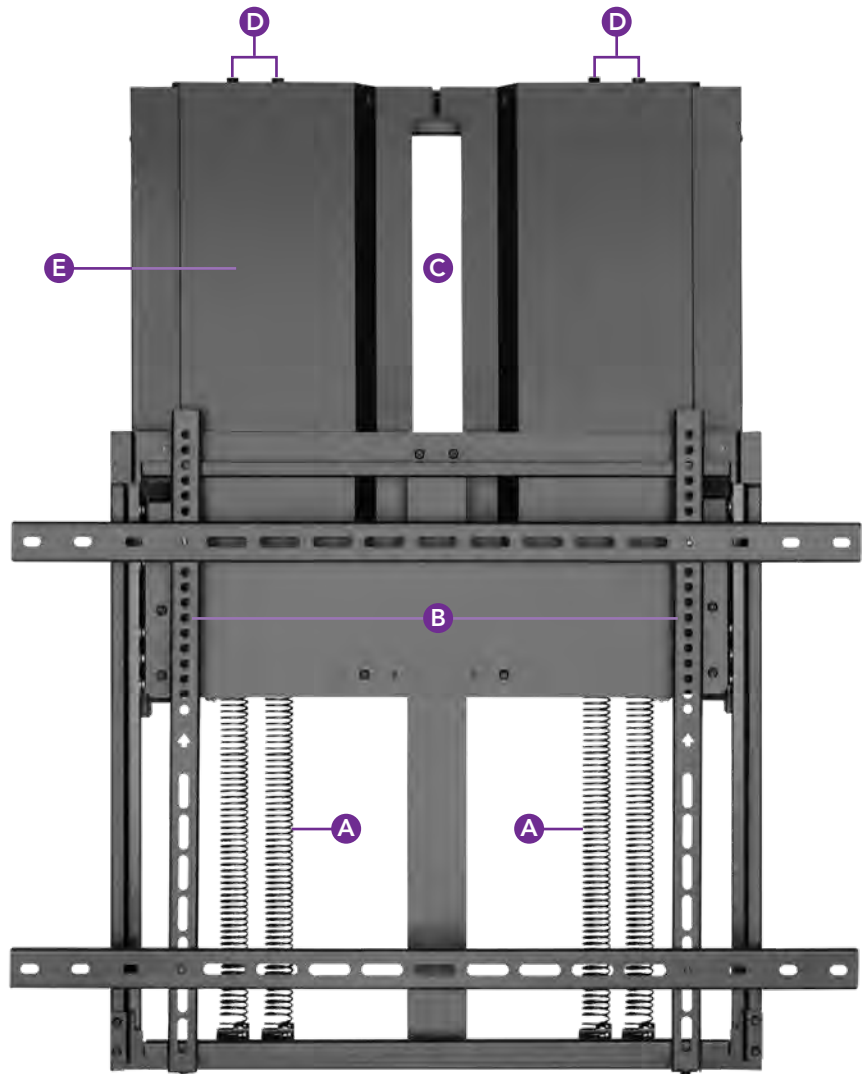

Model: DWM7090HD



SPECIFICATIONS

Model	DWM5070HD	DWM7090HD
Supported Screen Sizes	50 to 70 in. (127 - 178 cm)	70 to 90 in. (178 - 229 cm)
Weight Capacity	132 lb. (60 kg)	198 lb. (90 kg)
Vertical Adjustment Range	15.7 in. (40 cm)	15.7 in. (40 cm)
Motion	Full	Full
Mounting Profile (Surface to Display)	5 in. (12.7 cm)	5 in. (12.7 cm)
Supported VESA Patterns (mm)	200x200; 200x300; 200x400; 300x200; 300x300; 300x400; 400x200; 400x300; 400x400; 400x500; 400x600; 600x300; 600x400; 600x500; 600x600; 700x400; 700x500; 700x600; 800x400; 800x500; 800x600	
Construction	Powder-Coated Steel	Powder-Coated Steel
Warranty	5-Year Limited	5-Year Limited

Learn more about Tripp Lite's full line of display mounts at triplite.com.



Tripp Lite Corporate Headquarters

1111 West 35th Street, Chicago, IL 60609 USA
773.869.1773 | triplite.com