

GP Level REFER TO (P: 1) OR SAF

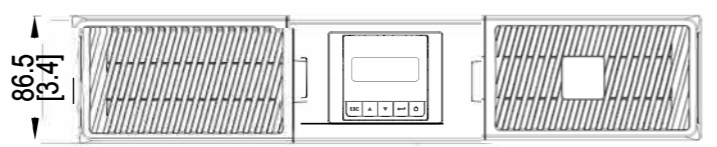
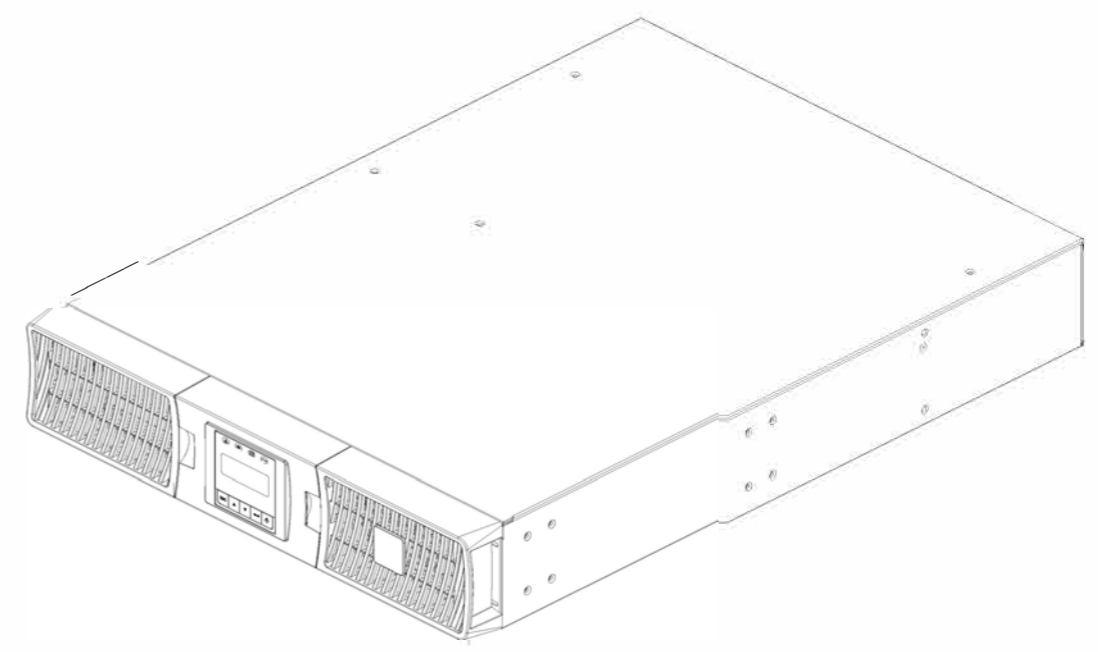
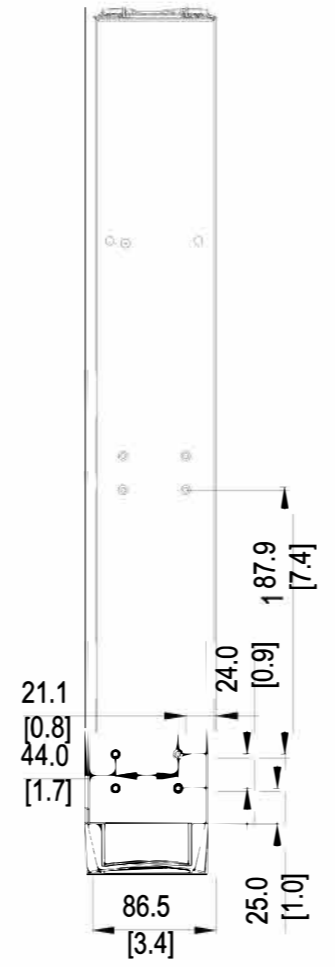
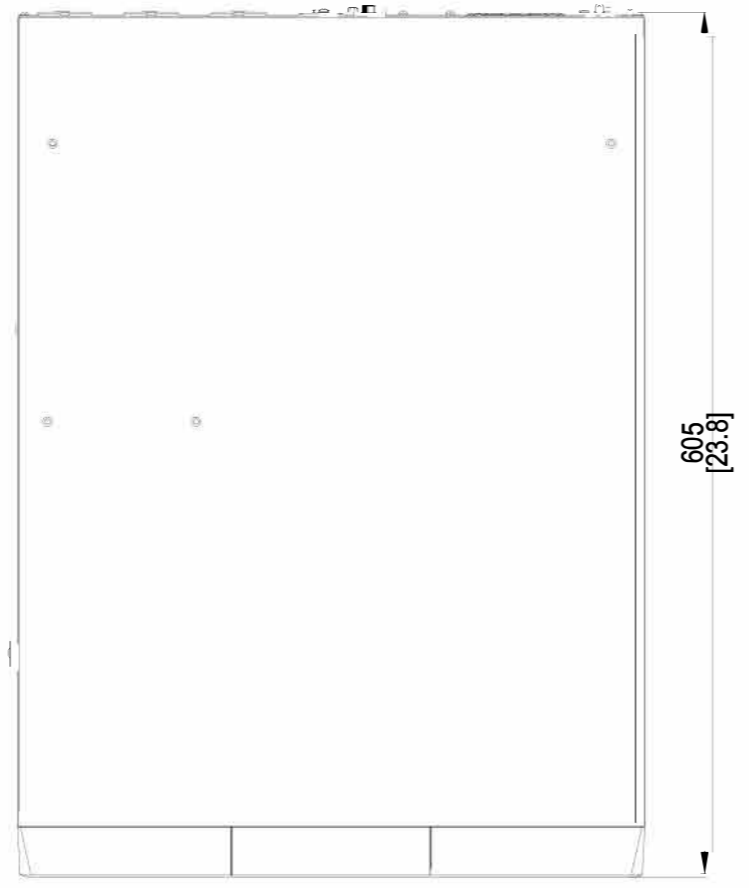
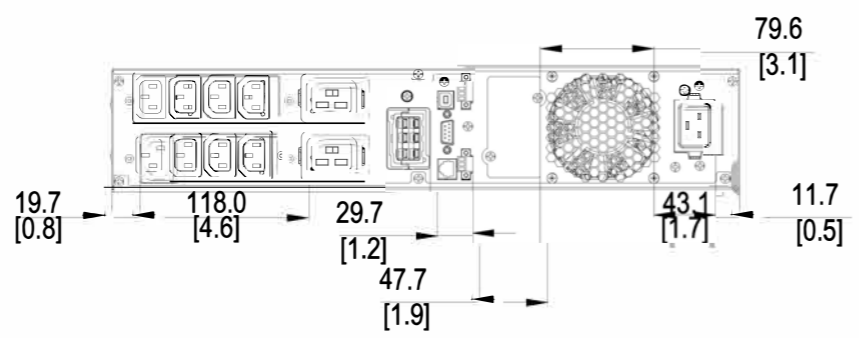

Notes:
 THIS DRAWING APPLIES 2U UPS models :
 SUINT2200LCD2U--->9103-73971-00
 SUINT3000LCD2U--->U9103-83A11-00

TITLE	TL Smart Online HV 2k/3k OUTLINE DRAWING	DRAW DESIGN	
PART NO.	IEC model	CHECKED	
MATERIAL		SAFETY	
COATING		APPROVED	
UNITS	mm	 A3 SCALE 1:1	 ©2024 Eaton. All rights reserved.
SHEET	1/1		