

NOTES:

RCD: (xxx+/-xx) STD: .xxx+/-xx(St) Key Dimension: *

1 RCD: Required Control Dimension ,These Dimensions need Process control & capability(initial and ongoing), 100%inspection, poke yoke, etc.as appropriate.

2 STD: Statistically Toleranced Dimension ,These Dimensions need demonstration of ongoing process capability (CpK/PpK).

3 Key Dimension:These Dimensions are defined by ME/Mfg,and need inspection as appropriate. If you want more information,please review the criterions of <TC-RDW-18>and<TC-QAW-40>

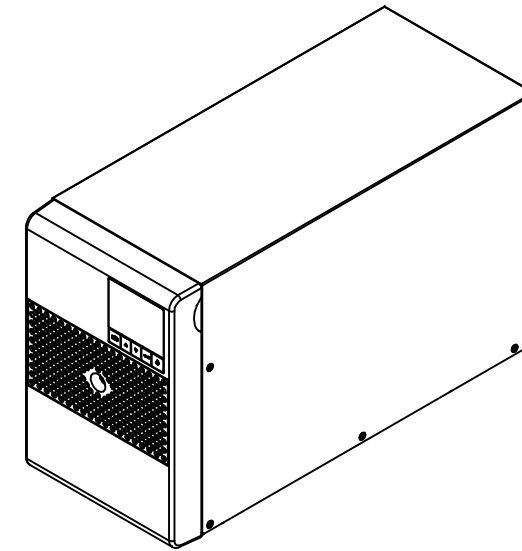
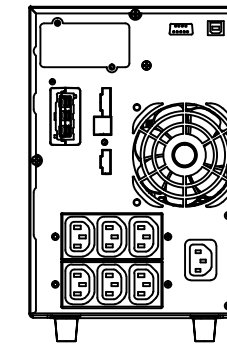
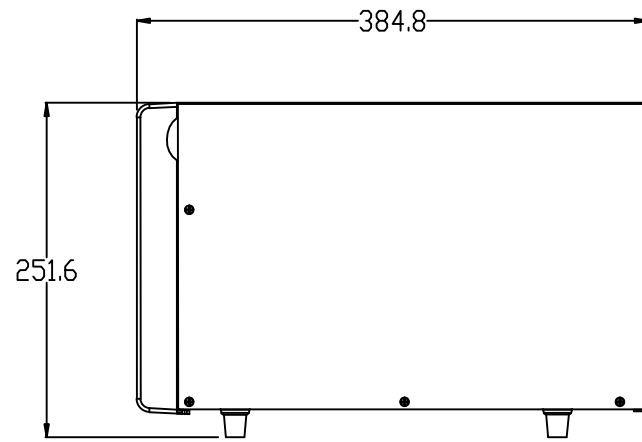
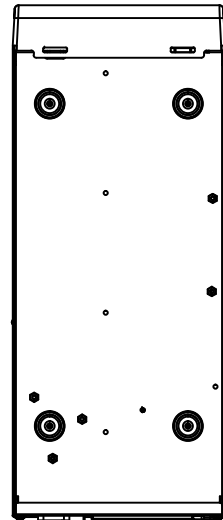
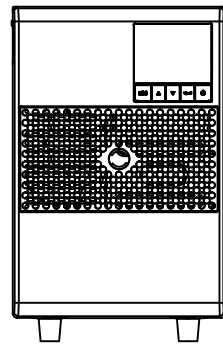
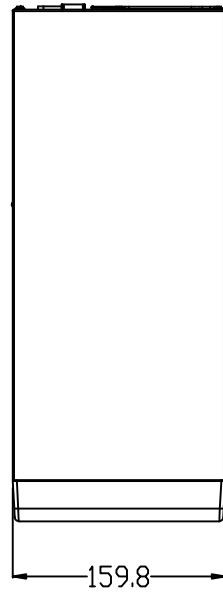

METRIC		EATON CORPORATION		
DIMENSIONS ARE IN MILLIMETERS AFTER PLATING, DIMENSIONS AND TOLERANCES IN ACCORDANCE WITH ASME Y14.5M-1994. SEE NOTES FOR TOLERANCES.				
DESCRIPTION:				
ORIGINATED: Daniel Tan	ECD:	NAME:	REVISION:	SIZE: A2
MODIFIED: Daniel Tan		9SX TOWER 1000 EU&G	STATE:	SCALE:
CHECKED:	DOCUMENT TYPE:	OUTLET DRAWING		1,000
SAFETY:	PRO-E DRAWING			SHEET:
APPROVED:				1 OF 1
EATON CORPORATION - CONFIDENTIAL AND PROPRIETARY				
NOTICE TO PERSONS RECEIVING THIS DOCUMENT AND/OR TECHNICAL INFORMATION				
THIS DOCUMENT, INCLUDING THE DRAWING AND INFORMATION CONTAINED THEREON, IS CONFIDENTIAL AND IS THE EXCLUSIVE PROPERTY OF EATON CORPORATION, AND IS HEREBY ON LOAN AND SUBJECT TO RECALL BY EATON AT ANY TIME. BY TAKING POSSESSION OF THIS DOCUMENT, THE RECIPIENT ACKNOWLEDGES AND AGREES THAT THIS DOCUMENT CANNOT BE USED IN ANY MANNER ADVERSE TO THE INTERESTS OF EATON AND THAT NO PORTION OF THIS DOCUMENT MAY BE COPIED OR OTHERWISE REPRODUCED WITHOUT THE PRIOR WRITTEN CONSENT OF EATON. IN THE CASE OF CONFLICTING CONTRACTUAL PROVISIONS, THIS NOTICE SHALL GOVERN THE STATUS OF THIS DOCUMENT.				