

SmartRack[®] top-of-rack precision cooling system

Single-rack cooling for server rooms, IT closets, micro data centers and edge computing applications

3.5 kW, 9U Height
208–240V, 60 Hz, UL listed

- Up to 3.5 kW (12 kBTU) cooling capacity
- Self-contained cooling system
- Also available bundled with matching 25U or 33U rack
- Variable-speed cooling for constant rack temperature
- Closely coupled to heat source for high efficiency and predictability
- Optional emergency ventilation
- Built-in remote management interface (SNMP, MODBUS TCP/IP)
- Large LCD touchscreen display for easy status monitoring and diagnostics



TRIPP·LITE
by **EAT·N**

Single-rack cooling for server rooms, IT closets, micro data centers and edge computing applications

As distributed IT increases in small and large networks, including edge computing, reliable cooling is critical. In addition, 5G-enabled technologies and IoT enclosures require compact cooling solutions that are easy to monitor and control remotely. The SmartRack top-of-rack precision cooling system is a network manageable, self-contained solution that does not require piping.

Key features and benefits

DEDICATED, SELF-CONTAINED COOLING

- **Close-coupled design:** Cooling positioned above IT gear reduces space requirements and improves energy efficiency.
- **Top-of-rack form factor:** Conserves data center white space by scaling vertically. Allows cold air to cascade downward and heat to rise naturally.
- **Internal condenser:** Self-contained system does not require piping, allowing quicker and easier deployment.
- **Matching 25U or 33U rack:** Optional rack cabinet is insulated and sealed to keep cold air inside and help prevent dust and debris from entering. Available bundled with cooling system.
- **Rack-type profile:** Integrates seamlessly with available matching racks and provides compatibility with most EIA-compliant rack cabinets \leq 33U.
- **Emergency ventilation:** Optional vent opens automatically in case of cooling failure to help prevent IT equipment from overheating. Inserts into reserved slot for easy installation.

HIGH PRECISION AND ENERGY EFFICIENCY

- **Inverter-driven compressor:** Variable-speed compressor provides precise temperature control and energy savings at partial load. Also enables soft start to avoid breaker tripping.
- **Front air discharge:** Directional airflow cascades cold air down the front of the rack across IT equipment air intakes.
- **Temperature and humidity sensors:** Real-time monitoring of heat load enables real-time cooling adjustments.
- **Advanced onboard controller:** Monitors and optimizes cooling operation.
- **Electronic expansion valve:** Provides maximum stability and reliability of the cooling system.
- **Water evaporator:** Removes excess moisture from the air inside the rack cabinet and evaporates condensate into the condenser output air without requiring a drain, pump or piping.

EASY AND POWERFUL MANAGEMENT

- **7-inch color LCD touchscreen:** User-friendly touchscreen display allows intuitive navigation and control, as well as advanced menus for monitoring and diagnostics.
- **Built-in LX platform network management interface:** Enables SNMP-based remote monitoring, control and alerts.
- **Dehumidification control:** Reduces humidity in the rack to a user-defined setting.
- **Graphical plotting screen:** Graphs historical data of various sensors for effective startup and data tracking.
- **Advanced alarms:** Provide maximum system visibility and quick troubleshooting. Send alerts via SNMP to DCIM/NMS.

The 3.5 kW top-of-rack cooling system is available bundled with a matching 25U or 33U rack cabinet. It is also compatible with most EIA-compliant rack cabinets \leq 33U.



SRCOOL3KTP25U
(SRCOOL3KTP + SR25UBAC)



SRCOOL3KTP33U
(SRCOOL3KTP + SR33UBAC)

3.5 kW cooling system with matching 25U or 33U rack

Cooling System Components

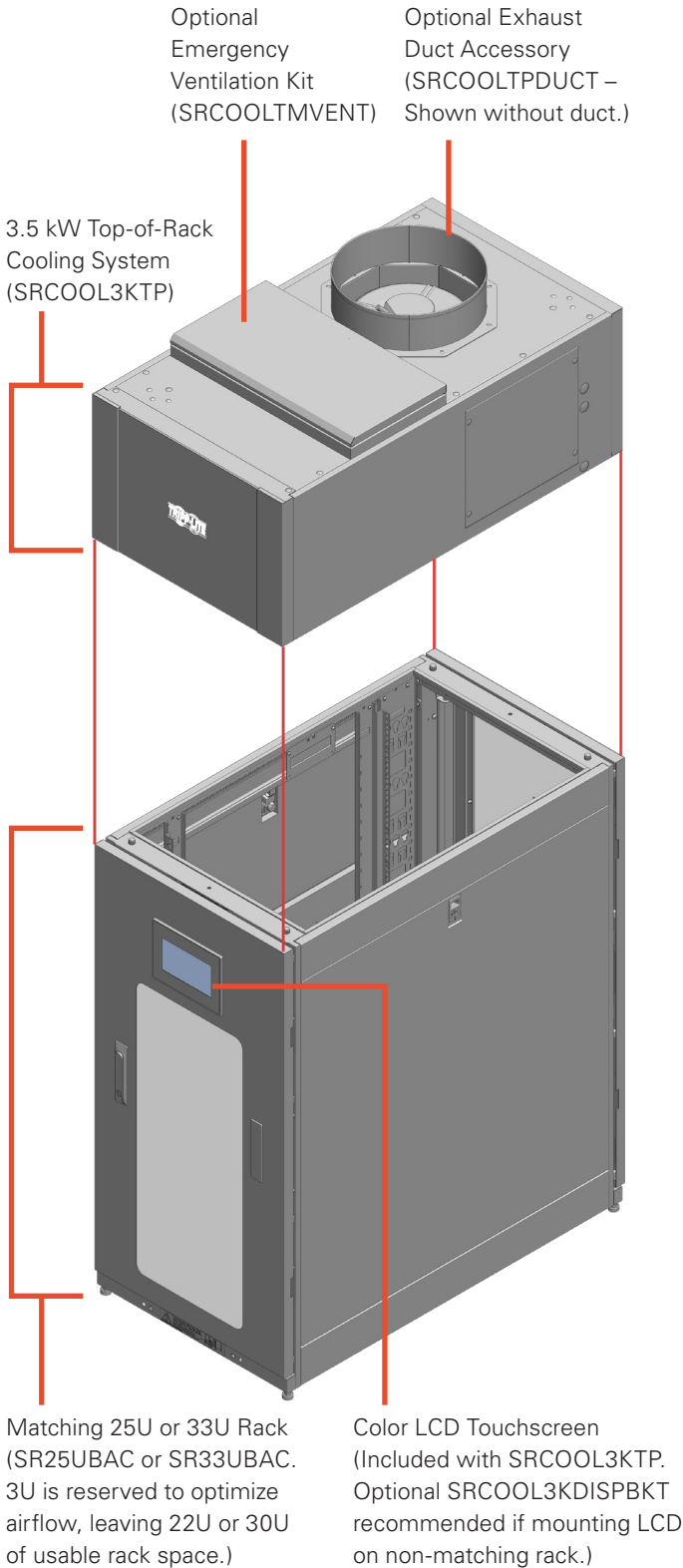

Airflow Overview (Side Cross-Section)

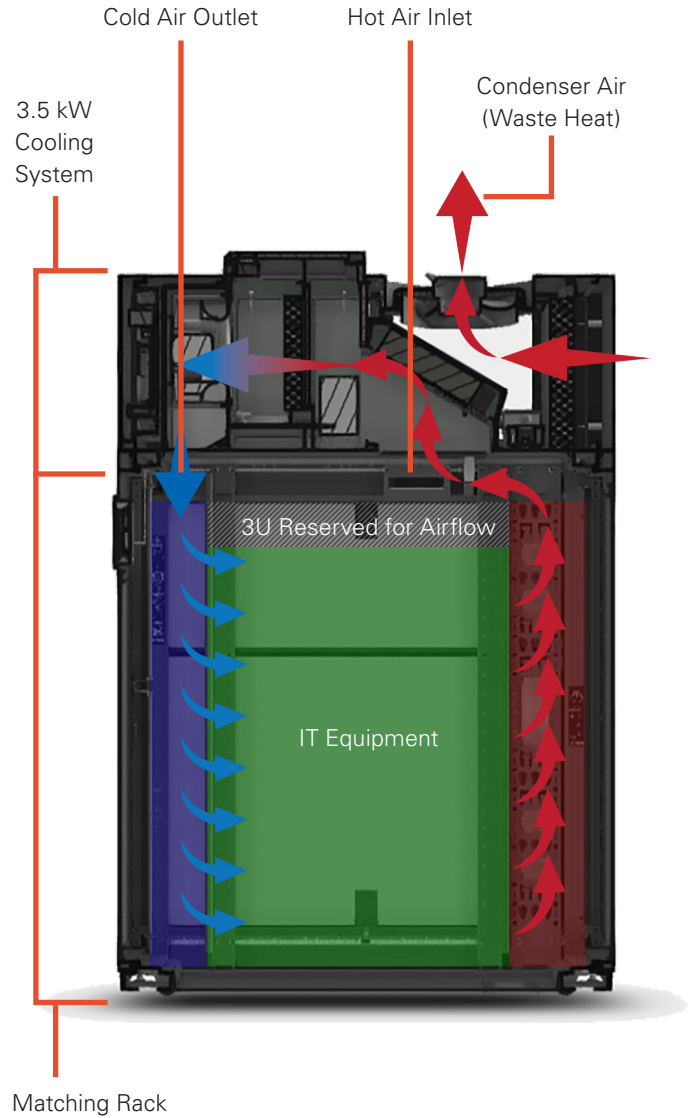

1. Cooling system captures hot exhaust air from IT equipment.
2. Cooling system cools hot air.
3. Condenser rejects waste heat outside rack cabinet.
4. Cooling system discharges cold air to front-panel air intakes of IT equipment.

Emergency ventilation

- Optional SRCOOLTMVENT accessory inserts directly into reserved slot for easy installation.
- Emergency ventilation helps prevent IT equipment from overheating in case of cooling system failure.
- Electromechanical fail-safe mechanism retains lid in place and embedded thermal sensor triggers lid release. Activation does not rely on cooling system.
- SNMP alert provides notification that the vent has opened.

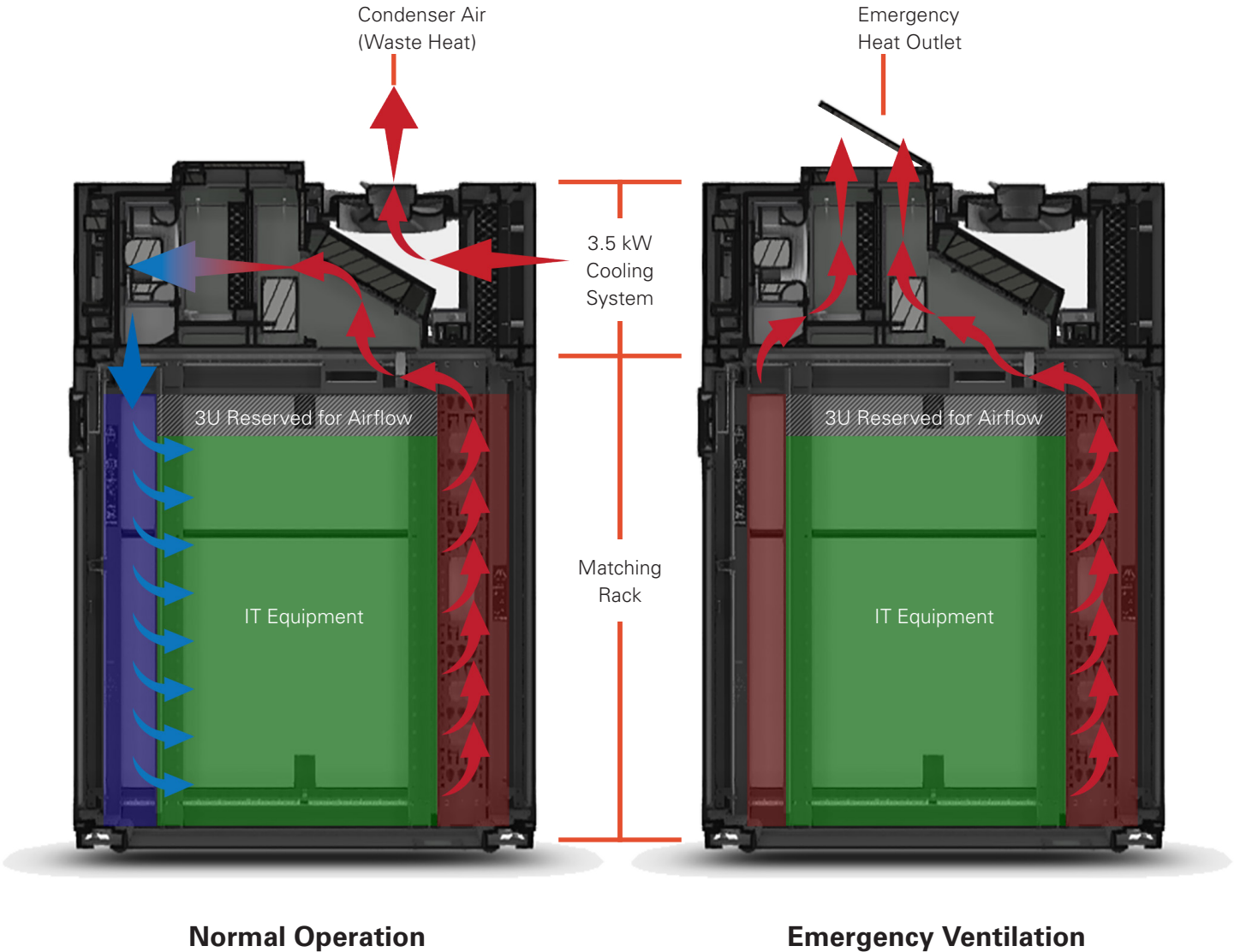

Dedicated cooling for single-rack edge micro data centers

Cool heat-sensitive rack-mount equipment in any of these locations:

NETWORK CLOSETS

IDF/MDF – On-premises computing for edge.

RETAIL AND COMMERCIAL

Branch location – Point-of-sale IT, IT management, branch office networking.

Back office – Dedicated application hosting for local clients.

Storefront – Facial recognition, customer experience applications.

LIGHT INDUSTRIAL

Factory – Machinery, imaging, processing, aggregation.

Warehouse – IT for order management.

Logistics and Distribution – IT for local applications to optimize and monitor workflow.

RESEARCH AND DEVELOPMENT

Laboratory – Cooling for single rack of lab IT equipment.



Powerful local management is at your fingertips

The color LCD touchscreen allows you to configure and operate the entire system from the onboard user interface.

- Easily change a variety of operational settings, adjust temperature, adjust airflow or turn on/off.
- View real-time system status and performance indicators.
- Graph operational and performance parameters in real-time for a holistic view of system behavior.
- View alarm notifications and the data log to better understand system behavior and diagnose issues.



Powerful network management is only a click away

The built-in LX platform network management interface enables remote monitoring and control through HTML5 web via HTTPS and SNMP for integration with management software platforms, including DCIM. The network management interface provides real-time automated status and alarm notifications to optimize system uptime and provide peace of mind. The cooling system also includes MODBUS TCP/IP.

Free PowerAlert® Network Management System software is downloadable at tripplite.com/poweralert.

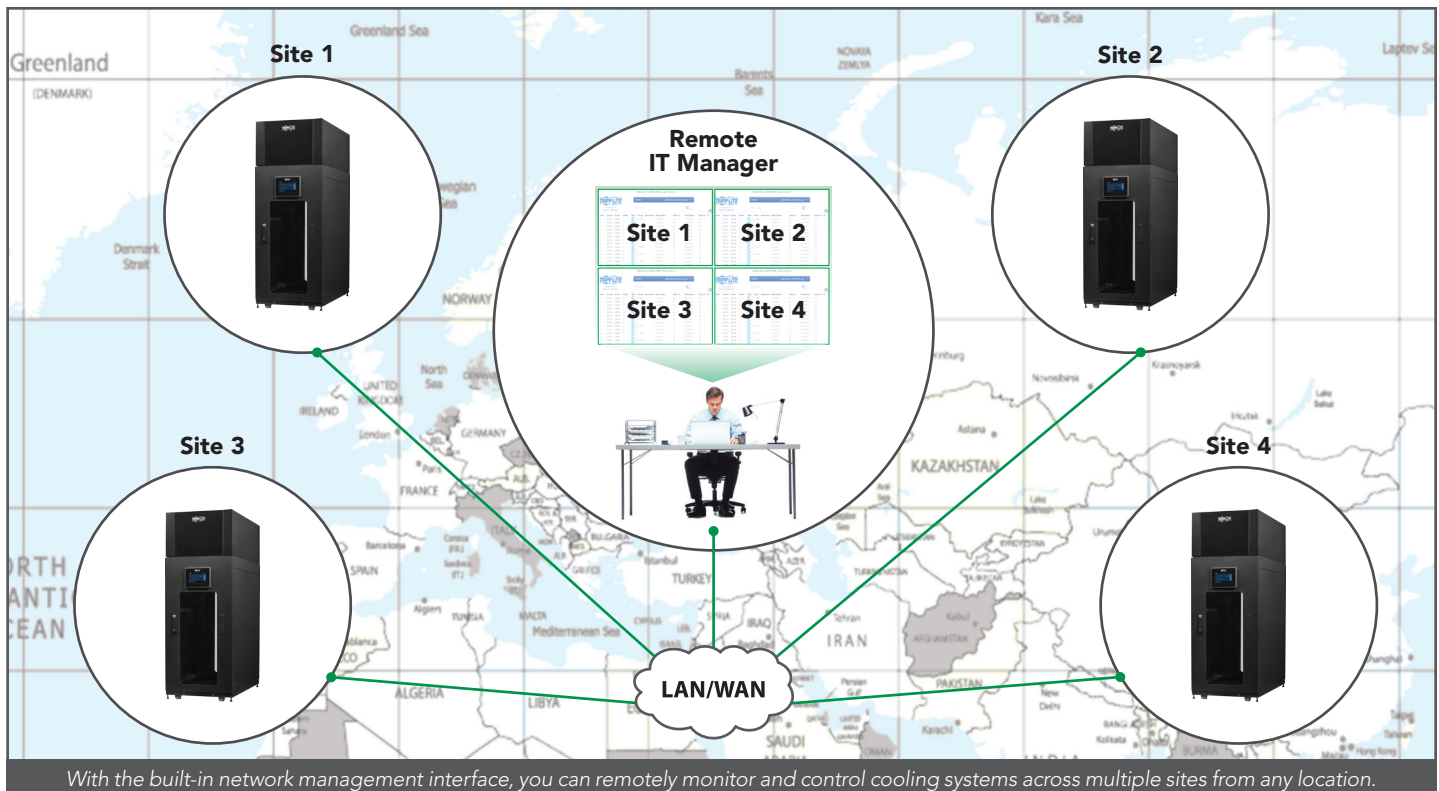

SPECIFICATIONS

Model	SRCOOL3KTP
Total Capacity	3.5 kW (12 kBTU/h)
Set Point Temperature Range	64° to 99° F (18° to 37° C)
Maximum Rejected Heat	4.3 kW
Air Circulation	350 CFM
Mounting Type	Top of Rack (Compatible with most EIA-compliant racks ≤ 33U.)
Cooling Type	Direct Expansion (DX)
Refrigerant Type	R410A
Unit Height	15.4 in. (39 cm)
Unit Width	23.6 in. (60 cm)
Unit Depth	43.3 in. (110 cm)
Unit Weight	168 lb. (76.2 kg)
Input Power	Single-Phase 208V, 60 Hz, 12.1A (Hardwire)
Input Voltage Range	Single-Phase 208–240V
Maximum Inrush Current	20A
Maximum Input Watts	3.5 kW
Peak EER	3.3
LCD Display	7 in. (18 cm) Touchscreen (Separate from cooling unit.)
Alarms (Function)	Yes (Water Leak, High/Low Temp, High Humidity, High/Low Pressure, Sensor Failure)
Communication Ports	RJ45 (SNMP), RJ45 (MODBUS TCP/IP)
SNMP Network Management	Yes (Includes LX platform network management interface.)
Flash Upgradable	Yes (LCD, controller and network management interface are flash upgradable.)
Standards	Tested to UL 60335; CSA, FCC Class B, NOM, RoHS

Note: Airflow is based upon rated setting. Fans modulate per real loads.

Cooling system, bundles and accessories

Model	Description
SRCOOL3KTP	3.5 kW top-of-rack cooling system.
SRCOOL3KTP25U	Bundle of 3.5 kW top-of-rack cooling system with matching 25U rack (SRCOOL3KTP + SR25UBAC).
SRCOOL3KTP33U	Bundle of 3.5 kW top-of-rack cooling system with matching 33U rack (SRCOOL3KTP + SR33UBAC).
SR25UBAC	25U semi-air-sealed SmartRack cabinet designed to match SRCOOL3KTP.
SR33UBAC	33U semi-air-sealed SmartRack cabinet designed to match SRCOOL3KTP.
SRCOOL3KDISPBKT	Bracket to mount SRCOOL3KTP display on non-matching and third-party EIA-compliant racks.
SRCOOLTMVENT	Emergency ventilation kit for SRCOOL3KTP.
SRCOOLTPDUCT	Exhaust duct accessory for SRCOOL3KTP.

Web resources

Browse cooling systems and accessories at tripplite.com to find the optimal solutions for your application, including the latest models and specifications.

For your convenience, design files are also provided for use in engineering and architectural projects.

Visit the cooling solutions page: tripplite.com/cooling.

Reliable and flexible service and support

Service is critical to maintaining optimal performance of SmartRack precision cooling systems. A range of services are designed to protect your products over their entire life cycle, from commissioning to preventive maintenance. They keep cooling systems in peak condition.

Warranty

The standard factory warranty for SmartRack top-of-rack precision cooling systems is one year. Optional extended warranties are available.

Commissioning

Commissioning builds a solid foundation for improved reliability, higher efficiency, reduced costs, enhanced safety, fewer repairs, quicker service and a longer lifespan. Commissioning helps you verify and document the proper installation and startup of your cooling system. Commissioning also registers your product, initiates its service record and establishes a working relationship between your organization and the service team. Lastly, commissioning activates a one-year on-site warranty, which covers parts, travel and labor.

Annual Service Agreements with Preventive Maintenance

Annual service agreements include on-site warranties and on-site preventive maintenance visits. Regular preventive maintenance significantly reduces failure rates by identifying potential threats early and correcting problems before they cause downtime. Component failures can still happen, but on-site warranties minimize the cost and disruption of unavoidable repairs.

Non-Warranty Services

Non-warranty services such as preventive maintenance or repair services are available when your cooling system is outside the warranty or service agreement period. Non-warranty services are quoted on a case-by-case, time-and-materials basis, and cost depends on the cooling system model and specific service requested.

Note: Service availability and specifications vary with location and model.



Contact us for more information:

+1.773.869.1236 | solutions@tripplite.com

© 2022 Eaton. All rights reserved. Eaton is a registered trademark.

All other trademarks are property of their respective owners.

TRIPP-LITE
by **EATON**

1111 W. 35th Street | Chicago, IL 60609

773.869.1773 | tripplite.com